

CATALOGUE OF



ISSUED BY

BSA MOTOR CYCLES LTD.

Service Department

MONTGOMERY STREET

BIRMINGHAM 11

TELEPHONE BIRMINGHAM VICTORIA 2234
TELEGRAMS "SELSERV" BIRMINGHAM

B.S.A. MOTOR CYCLES LTD.

Registered Offices and Works: ARMOURY ROAD, BIRMINGHAM

Telephones: BIRMINGHAM VICTORIA 2381 *Telegrams and Cables:* "SELMOTO BIRMINGHAM"

Contractors to Her Majesty's Government, the War Office, the Admiralty, the Post Office, the Colonial and Foreign Governments

SUFFIX NUMBERS TO BE USED TO IDENTIFY VARYING FINISHES

/001	Cadmium
/003	Bright Chrome
/007	Black Enamel
/44	Chromium with Black Hubs
/99	Petrol Tank, Bayard Crimson with Ivory Panels and Gold Lining
/105	Bayard Crimson
/125	Chromium with Bayard Crimson Hubs
/126	Petrol Tank, Black with Ivory Panels and Gold Lining

When Ordering components with varying finishes, i.e., Petrol Tanks, Wheels, Rims, Brake Rods, Front Fork Oil Seal Holder—please state finish required by adding the appropriate number to part number.

EXAMPLE. Petrol Tank, Bayard Crimson with Ivory Panels 90-8045/99.

SPARKING PLUGS

CHAMPION SPARKING PLUGS LTD., FELTHAM, MIDDLESEX

ELECTRICAL EQUIPMENT

J. LUCAS LTD., GREAT KING STREET, BIRMINGHAM

SPEEDOMETERS

SMITH'S MOTOR ACCESSORIES, CRICKLEWOOD WORKS, LONDON

INDEX, GRUPPEVERZEICHNIS, INDICE

PAGE
PAGE
SEITE
PÁGINA

ENGINE	MOTEUR	MOTOR	MOTOR	12
ENGINE AND GEARBOX	MOTEUR ET BOITE VITESSES	MOTOR UND GETRIEBE	MOTOR Y CAJA DE VELOCIDADES	16
GEARBOX	BOITE DE VITESSES	GETRIEBE	CAJA DE VELOCIDADES	18
FRAME	CADRE	RAHMEN	CUADRO	22
FRONT FORK	FOURCHE AV	VORDERGABEL	HORQUILLA DEL	28
FRONT WHEEL	ROUE AV	VORDERRAD	RUEDA DELANTERA	30
REAR WHEEL	ROUE AR	HINTERRAD	RUEDA TRASERA	32
MUDGUARDS	GARDEBOUE	SCHUTZBLECHE	GUARDABARROS	34
MUDGUARDS CHAINGUARD TOOLBOX	GARDEBOUE CARTER DE CHAINE COFFRET Á OUTILS	SCHUTZBLECHE KETTERNKASTEN WERKZEUGBENHALTER	GUARDABARROS GUARDACADENA CAJA DE HERRAMIENTOS	36
DUAL SEAT	SELLE DOUBLE	DOPPELSITZ	ASIENTO DOBLE	38
PETROL TANK HANDLEBAR SILENCER	RESEVOIR Á CARBURANT GUIDON SILENCIEUX	KRAFTSTOFFBEHALTER LENKER AUSPUFFTOPF	DEPOSITO DE COMBUSTIBLE MANILLAR SILENCIADOR	40
LEGSHIELDS SAFETY BARS	PROTÉGÉ-JAMBE PARE-CHOS	BEINSCHILD STURZBOGEN	GUARDAPIERNAS BARAS DE SEGURIDAD	42
ELECTRICAL EQUIPMENT	EQUIPEMENT ELECTRIQUE	ELEKTR. AUSRÜSTUNG	EQUIP ELECTRICO	44
TOOLS	OUTILS	WERKZEUGER	HERRAMIENTOS	46

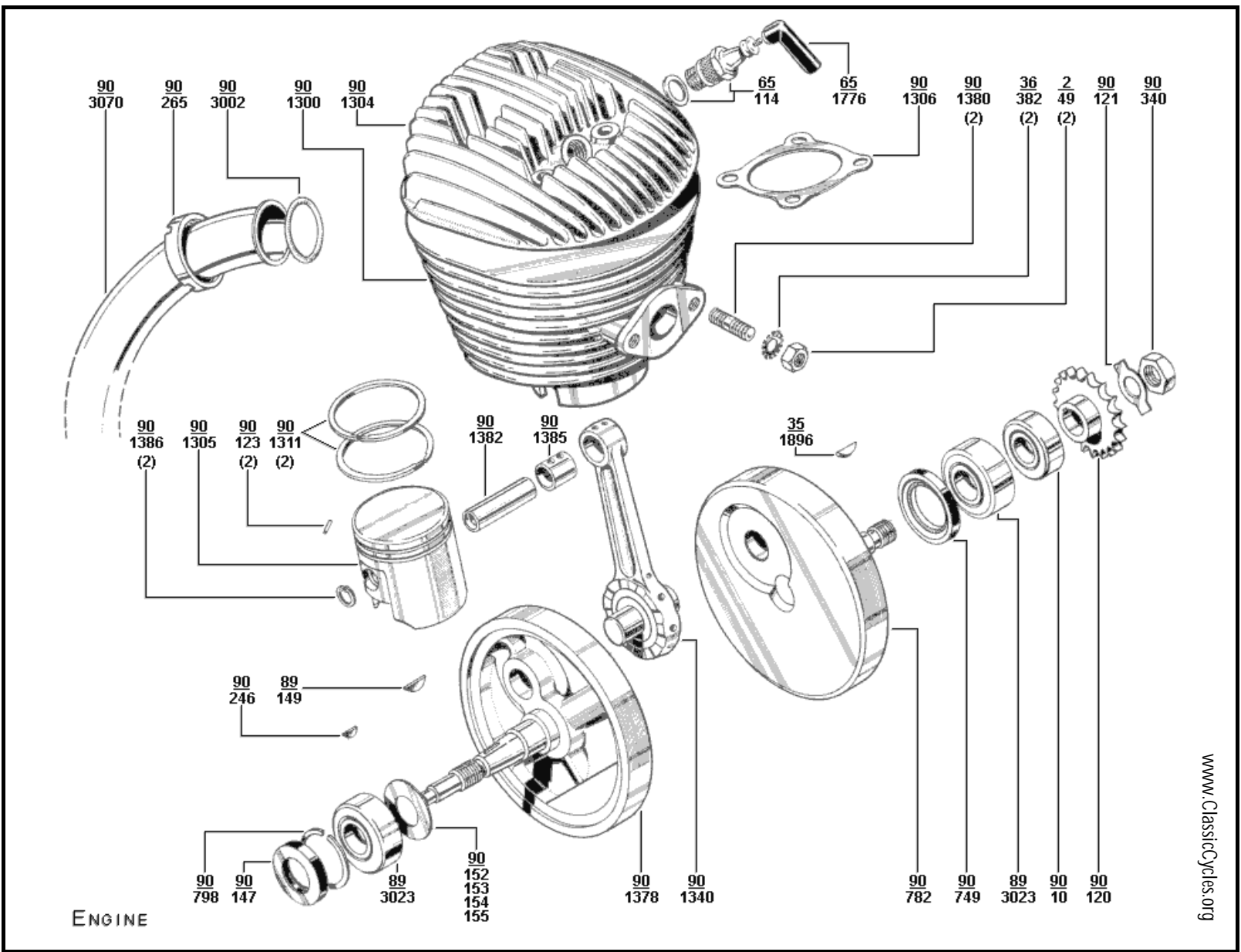

ENGINE

ENGINE, MOTEUR, MOTOR

Part No. No. De Commande Bestell - Nr No. DeParte	Description	Designation	Benennung	Descripción	Per Set Nombre Anzahl Juego De
2-49	Nut	Ecrou	Mutter	Tuerca	2
35-1896	Woodruff Key	Clavette Woodruff	Scheibenfeder	Chaveta Woodruff	
36-382	Lockwasher	Arrêtoir	Sicherung	Freno	2
65-114	Spark Plug	Bougie D' Allumage	Zündkerze	Bujía	
65-1776	IG. Lead Terminal	Borne De Cable D' Allumage	Zündleitungsstecker	Borne De Conexion	
89-149	Woodruff Key	Clavette Woodruff	Scheibenfeder	Chaveta Woodruff	
89-3023	Ball Bearing	Roulement	Lager	Rolamiento	2
90-10	Ball Bearing	Roulement	Lager	Rolamiento	
90-120	Engine Sprocket	Pignon Moteur	Motor Ritzel	Piñon De Motor	
90-121	Lockwasher	Arrêtoir	Sicherung	Freno	
90-123	Piston Ring Peg	Goupille	Sicherungsstift	Clavija	2
90-147	Oil Seal	Joint D' Huile	Dichtring	Reten De Aceite	
90-152	Shim (.003")	Rondelle D' Epaisseur (.0762 mm.)	Ausgleich (.0762 mm.)	Espesor	
90-153	Shim (.004")	Rondelle D' Epaisseur (.1062 mm.)	Ausgleich (.1062 mm.)	Espesor	
90-154	Shim (.005")	Rondelle D' Epaisseur (.127 mm.)	Ausgleich (.127 mm.)	Espesor	
90-155	Shim (.010")	Rondelle D' Epaisseur (.254 mm.)	Ausgleich (.254 mm.)	Espesor	
90-246	Woodruff Key	Clavette Woodruff	Scheibenfeder	Chaveta Woodruff	
90-265	Nut	Ecrou	Mutter	Tuerca	
90-340	Nut	Ecrou	Mutter	Tuerca	
90-749	Oil Seal	Joint D' Huile	Dichtring	Reten De Aceite	
90-782	Crankshaft R/H	Vilebrequin-Droit	Kurbelwelle-Rechts	Cigüenal-Derecho	
90-798	Circlip	Arrêtoir	Sicherung	Freno	
90-1300	Cylinder	Cylindre	Zylinder	Cilindro	
90-1304	Cylinder Head	(Cylindre) Culasse	Zylinderkopf	Culata	
90-1305	Piston Complete	Piston Complète	Kolben Vollst	Embolo Comp	
90-1306	Gasket	Joint	Dichtung	Empaquetadura	
90-1311	Piston Ring	Segment	Verdichtungsring	Segmento	2
90-1340	Conn. Rod Assembly	Bielle Complète	Plauel Stange Komp	Biela Comp	
90-1349	Piston Complete (plus ½ mm.)	Piston Complète (plus ½ mm.)	Kolben Vollst (plus ½ mm.)	Embolo Comp	
90-1351	Piston Complete (plus 1 mm.)	Piston Complète (plus 1 mm.)	Kolben Vollst (plus 1 mm.)	Embolo Comp	
90-1378	Crankshaft L/H	Vilebrequin-Gauche	Kurbelwelle-Links	Cigüenal-Izquierdo	
90-1380	Stud	Goujon	Stehbolzen	Esparrago	2
90-1382	Gudgeon Pin	Axe De Piston	Kolbenbolzen	Bulón De Embolo	
90-1385	Bush	Douille	Büchse	Casquillo	
90-1386	Circlip	Arrêtoir	Sicherung	Freno	2
90-3002	Sealing Ring	Bague D' Etanchéité	Dichtring	Junta	
90-3070	Exhaust Pipe	Tuyau D' Echappement	Auspuffrohr	Tube De Escape	

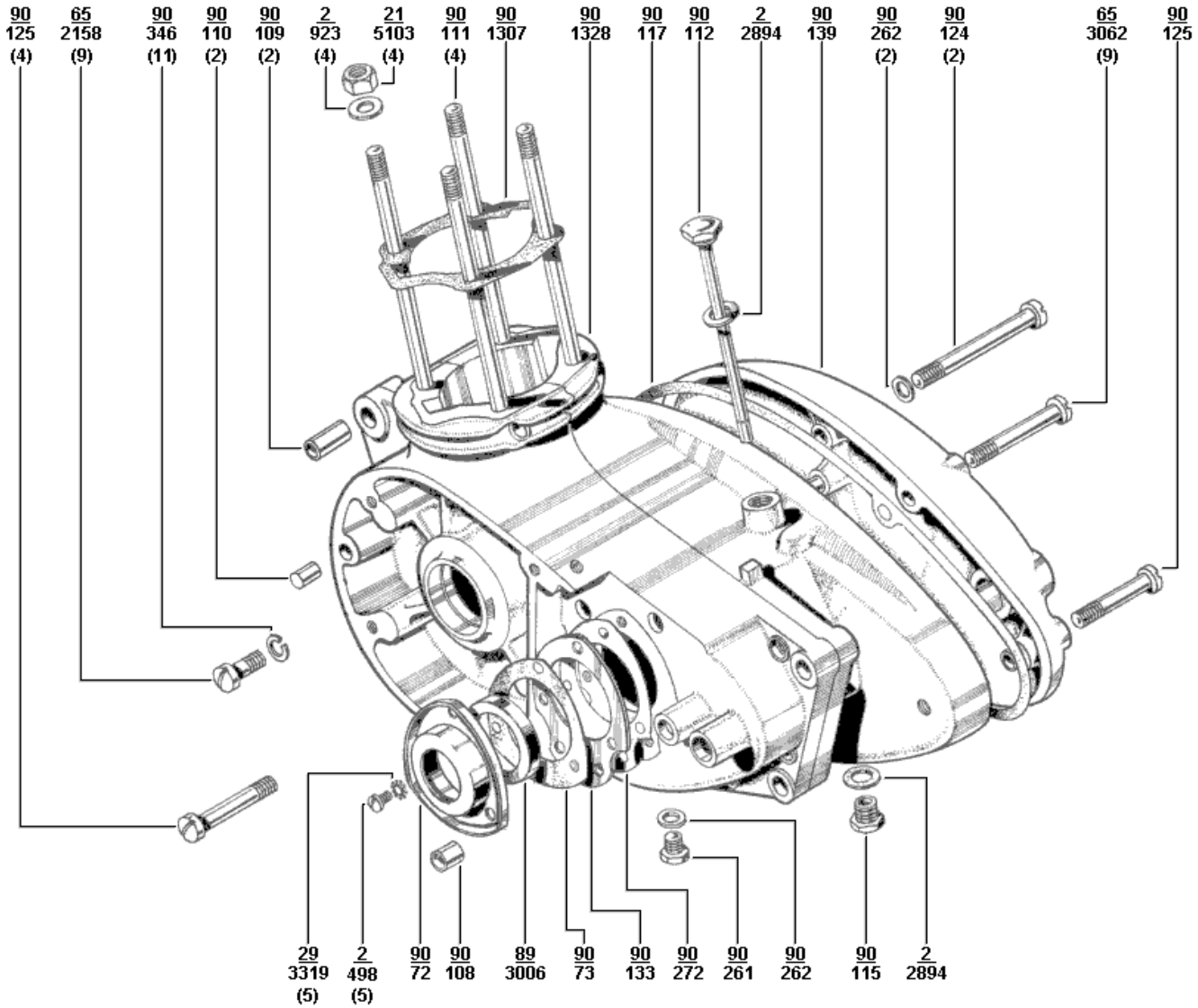

ENGINE AND GEARBOX

ENGINE, MOTEUR, MOTOR

Part No. No. De Commande Bestell - Nr No. DeParte	Description	Designation	Benennung	Descripción	Per Set Nombre Anzahl Juego De
2-498	Screw	Vis	Schraube	Tornillo	5
2-923	Washer	Rondelle	Scheibe	Arandela	4
2-2894	Sealing Washer	Joint	Dichtung	Arandela De Reten	2
21-5103	Nut	Ecrou	Mutter	Tuerca	4
29-3319	Lockwasher	Arrêtoir	Sicherung	Freno	5
65-2158	Screw	Vis	Schraube	Tornillo	9
65-3062	Screw	Vis	Schraube	Tornillo	2
89-3006	Oil Seal	Joint D'Huile	Dichtring	Reten De Aceite	
90-72	Oil Seal Housing	Boitier De Joint D'Huile	Dichtring Gehäuse	Caja-Raten De Aceite	
90-73	Gasket	Joint	Dichtung	Empaquetadura	
90-108	Dowel	Goupille Cylindrique	Stift	Pasador	
90-109	Spacer Tube	Tube Entretoise	Abstandrohr	Tube Espaciador	2
90-110	Dowel	Goupille Cylindrique	Stift	Pasador	2
90-111	Stud	Goujon	Stehbolzen	Esparrago	4
90-112	Dipstick	Réglette-Jauge	Ölmess Stab	Varilla Probadora	
90-115	Drain Plug	Bouchon De Vidange D'Huile	Abluss Schraube	Tapón	
90-117	Gasket	Joint	Dichtung	Empaquetadura	
90-124	Screw	Vis	Schraube	Tornillo	2
90-125	Screw	Vis	Schraube	Tornillo	5
90-133	Bearing Thrust Plate	Plaque De Butée-Roulement	Lager Druckscheibe	Placa De Empuje	
90-139	Clutch Cover	Couvercle	Deckel	Tapa	
90-261	Drain Plug	Bouchon De Vidange D'Huile	Abluss Schraube	Tapón	
90-262	Washer	Rondelle	Scheibe	Arandela	7
90-272	Gasket	Joint	Dichtung	Empaquetadura	
90-346	Lockwasher	Arrêtoir	Sicherung	Freno	11
90-1307	Gasket	Joint	Dichtung	Empaquetadura	
90-1328	Crankcase	Carter De Vilebrequin	Kurbelgenhalise	Caja De Cihüenal	

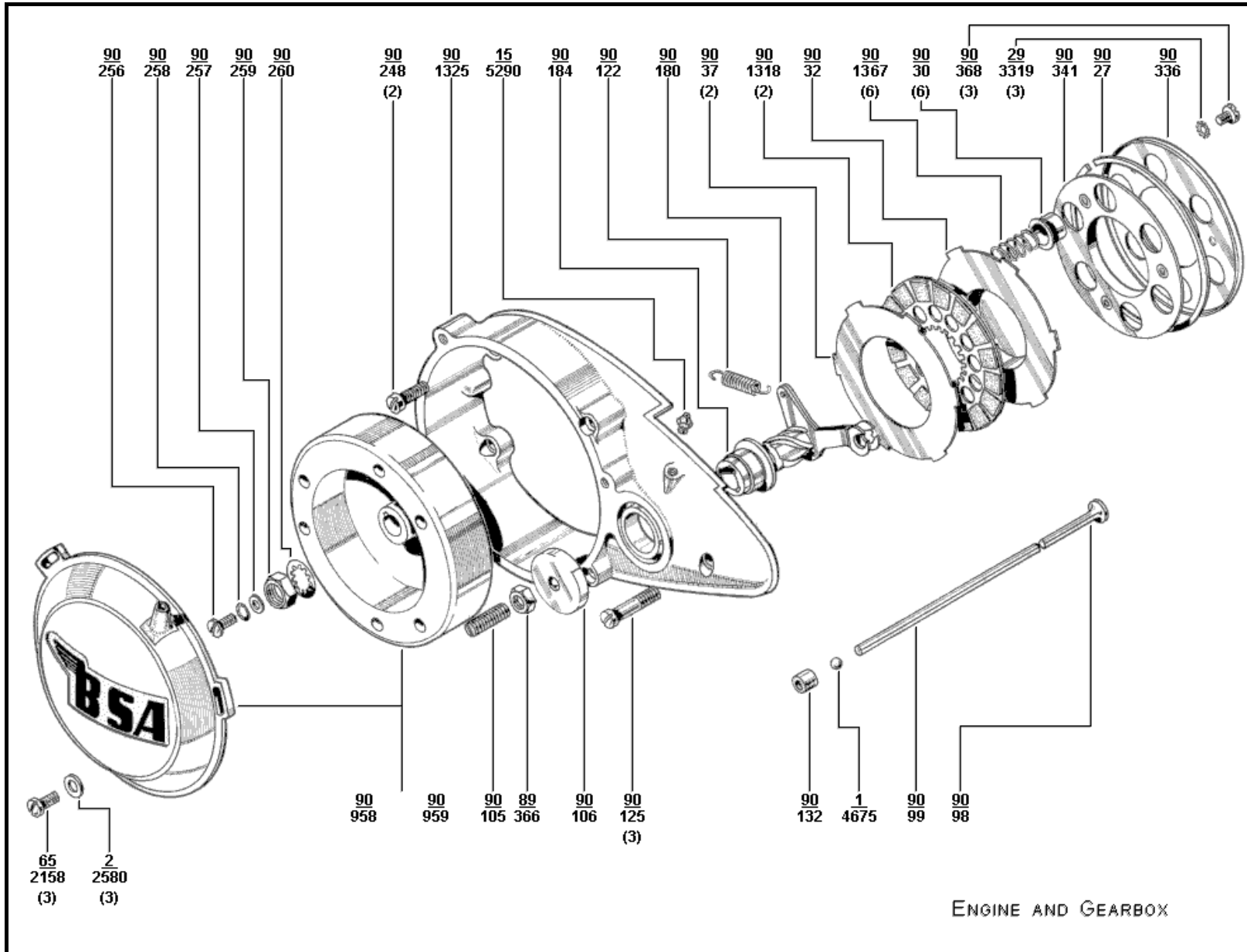

ENGINE AND GEARBOX, MOTEUR ET BOITE DE VITESSES MOTOR UND GETRIEBE, MOTOR Y CAJA VELOCIDADES

Part No. No. De Commande Bestell - Nr No. DeParte	Description	Designation	Benennung	Descripción	Per Set Nombre Anzahl Juego De
1-4675	Ball	Bille	Kugel	Bola	
2-2580	Washer	Rondelle	Scheibe	Arandela	3
15-5290	Grease Nipple	Graisser	Schmiernippel	Engrasador	
29-3319	Lockwasher	Arrêtoir	Sicherung	Freno	3
65-2158	Screw	Vis	Schraube	Tornillo	3
89-366	Nut	Ecrou	Mutter	Tuerca	
90-27	Spring Clip	Arrêtoir	Sicherung	Freno	
90-30	Spring Cup	Douille	Hülse	Copa	6
90-32	Clutch Back Plate	Plateau D'Embrayage	Kupplungsscheibe	Placa Del Embrague	
90-37	Driven Plate	Disque Entraîné	Getriebenescheibe	Disco Accionado	2
90-98	Clutch Rod (Short)	Tige De Traction (Courte)	Zugstange (Kurz)	Varilla Del Embrague (Corta)	
90-99	Clutch Rod (Long)	Tige De Traction (Longue)	Zugstange (Lang)	Varilla Del Embrague (Larga)	
90-105	Stud	Goujon	Stehbolzen	Esparrago	
90-106	Cap	Rondelle Chapeau	Abdeckkappe	Tapon	
90-122	Spring	Ressort	Feder	Resorte	
90-125	Screw	Vis	Schraube	Tornillo	3
90-132	Bush	Douille	Büchse	Casquillo	
90-180	Operating Lever Inner	Levier Intérieur	Hebel Innen	Palanca Int	
90-184	Bush	Douille	Büchse	Casquillo	
90-248	Screw	Vis	Schraube	Tornillo	2
90-256	Screw	Vis	Schraube	Tornillo	
90-257	Washer	Rondelle	Scheibe	Arandela	
90-258	Lockwasher	Arrêtoir	Sicherung	Freno	
90-259	Nut	Ecrou	Mutter	Tuerca	
90-260	Lockwasher	Arrêtoir	Sicherung	Freno	
90-336	Cover Plate	Couvercle De Palier	Lagerdeckel	Tapa Del Cojinete	
90-341	Clutch Pressure Plate	Disque Extérieur D'Embrayage	Aussere Kupplungscheibe	Disco Exterior Del Embrague	
90-368	Screw	Vis	Schraube	Tornillo	3
90-958	Generator (D.C.)	Génératrice (C.D.)	Stromerzeuger (G)	Generador (C.D.)	
90-959	Generator (A.C.)	Génératrice (C.A.)	Stromerzeuger (W)	Generador (C.A.)	
90-1318	Driving Plate	Disque D'Entraînement	Mitnehmerplatte	Place De Manda	3
90-1325	Casing	Manchon	Hulle	Envoltura	
90-1361	Clutch Complete	Embrayage Et Commande Complète	Kupplung Vollst	Embrague Comp	
90-1367	Spring	Ressort	Feder	Resorte	6

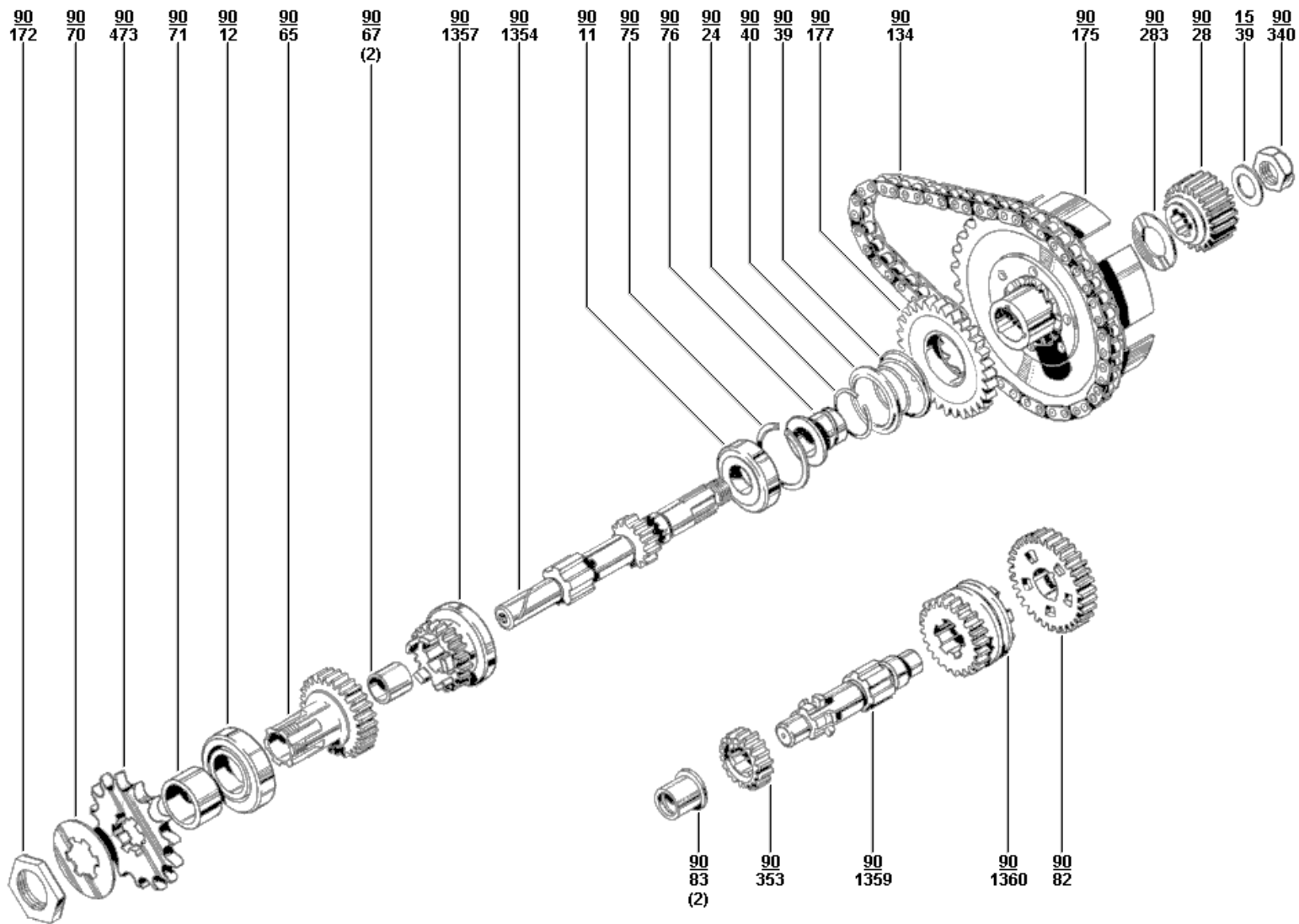

GEARBOX AND FITTINGS

GEARBOX AND FITTINGS, BOITE DE VITESSES GETRIEBE, CAJA DE VELOCIDADES

Part No. No. De Commande Bestell – Nr No. DeParte	Description	Designation	Benennung	Descripción	Per Set Nombre Anzahl Juego De
00-3117	Gasket Set	Jeu De Joints	Satz Dichtungen	Juego De Empaquetaduras	
15-39	Washer	Rondelle	Scheibe	Arandela	
90-11	Ball Bearing	Roulement	Lager	Rolamiento	
90-12	Ball Bearing	Roulement	Lager	Rolamiento	
90-24	Circlip	Arrêtoir	Sicherung	Freno	
90-28	Clutch Centre	Moyeux D' Embrayage	Kupplungsnahe	Cubo De Embrague	
90-39	Spring	Ressort	Feder	Resorte	
90-40	Spring Cup	Douille	Hülse	Copa	
90-65	Pinion	Pignon	Zahnrad	Piñón	
90-67	Bush	Douille	Büchse	Casquillo	2
90-70	Lockwasher	Arrêtoir	Sicherung	Freno	
90-71	Spacer Bush	Bague D'Écartement	Distanzring	Anillo Espaciador	
90-75	Circlip	Arrêtoir	Sicherung	Freno	
90-76	Spacer Bush	Bague D'Écartement	Distanzring	Anillo Espaciador	
90-82	Pinion 32T	Pignon D – 32	Zahnrad Z - 32	Piñón D – 32	
90-83	Bush	Douille	Büchse	Casquillo	2
90-134	Primary Chain	Chaine Primaire	Antriebskette	Cadena Motrice	
90-172	Nut	Ecrou	Mutter	Tuerca	
90-175	Clutch Chain Wheel	Pignon De Chaine-Embrayage	Kupplungsketten Rad	Piñón De Cadena Del Embrague	
90-177	Starter Pinion	Pignon Du Demarreur	Anlass Ritzel	Piñón De Arancador	
90-283	Thrust Washer	Rondelle De Butée	Druckscheibe	Anillo De Empuje	
90-340	Nut	Ecrou	Mutter	Tuerca	
90-353	Pinion 19T	Pignon D – 19	Zahnrad Z - 19	Piñón D – 19	
90-473	Gearbox Sprocket	Pignon De Boite de Vitesse	Getrieberitzel	Piñón De Caja De Velocidades	
90-1354	Mainshaft	Arbre Primaire	Getriebewelle	Árbol Principal	
90-1357	Pinion 22T	Pignon D – 22	Zahnrad Z - 22	Piñón D – 22	
90-1359	Layshaft	Arbre Secondaire	Vorgelegewelle	Árbol De Reenvio	
90-1360	Pinion 25T	Pignon D – 25	Zahnrad Z - 25	Piñón D – 25	

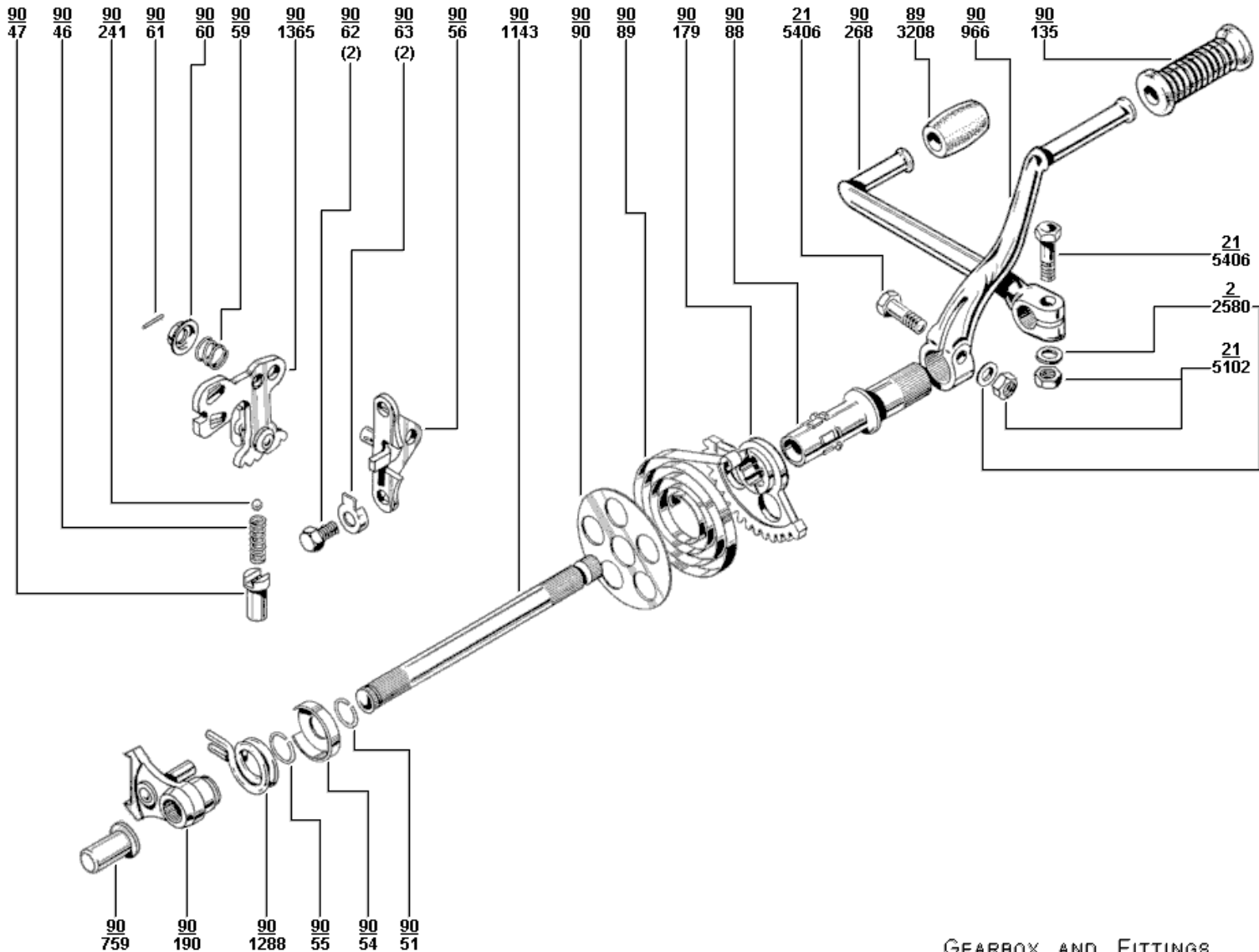

GEARBOX AND FITTINGS

GEARBOX AND FITTINGS, BOITE DE VITESSES GETRIEBE, CAJA DE VELOCIDADES

Part No. No. De Commande Bestell – Nr No. DeParte	Description	Designation	Benennung	Descripción	Per Set Nombre Anzahl Juego De
2-3117	Washer	Rondelle	Scheibe	Arandela	2
21-5102	Nut	Ecrou	Mutter	Tuerca	2
21-5406	Bolt	Boulon	Schraube	Tornillo	2
89-3208	Rubber Pad	Revetement Caoutchouc	Gummiauflage	Conjin De Goma	
90-46	Spring	Ressort	Feder	Resorte	
90-47	Spring Cup	Douille	Hülse	Copa	
90-51	Circlip	Arrêtoir	Sicherung	Freno	
90-54	Spring Cup	Douille	Hülse	Copa	
90-55	Circlip	Arrêtoir	Sicherung	Freno	
90-56	Bracket	Support	Lagerbock	Soporte	
90-59	Spring	Ressort	Feder	Resorte	
90-60	Spring Cup	Douille	Hülse	Copa	
90-61	Peg	Goupille	Sicherungstift	Esparrago	
90-62	Bolt	Boulon	Schraube	Tornillo	2
90-63	Lockwasher	Arrêtoir	Sicherung	Freno	2
90-88	Shaft	Arbre	Welle	Árbol	
90-89	Spring	Ressort	Feder	Resorte	
90-90	Plate	Plaque	Scheibe	Placa	
90-135	Rubber Pad	Revetement Caoutchouc	Gummiauflage	Conjin De Goma	
90-179	Quadrant	Secteur	Segment	Sector	
90-190	Selector Fork	Fourchette De Commande De Changement De Vitesses	Schaltgabel	Horquilla De Mando De Caja De Velocidades	
90-241	Ball	Bille	Kugel	Bola	
90-268	Lever	Levier	Hebel	Palanca	
90-759	Pad	Tampon	Auflage	Cojín	
90-966	Lever	Levier	Hebel	Palanca	
90-1143	Gearchange Spindle	Arbre De Commande De Changement De Vitesses	Schaltwelle	Arbol De Cambio	
90-1288	Spring	Ressort	Feder	Resorte	
90-1365	Ratchet Plate	Secteur	Segment	Segmento	

FRAME AND FITTINGS

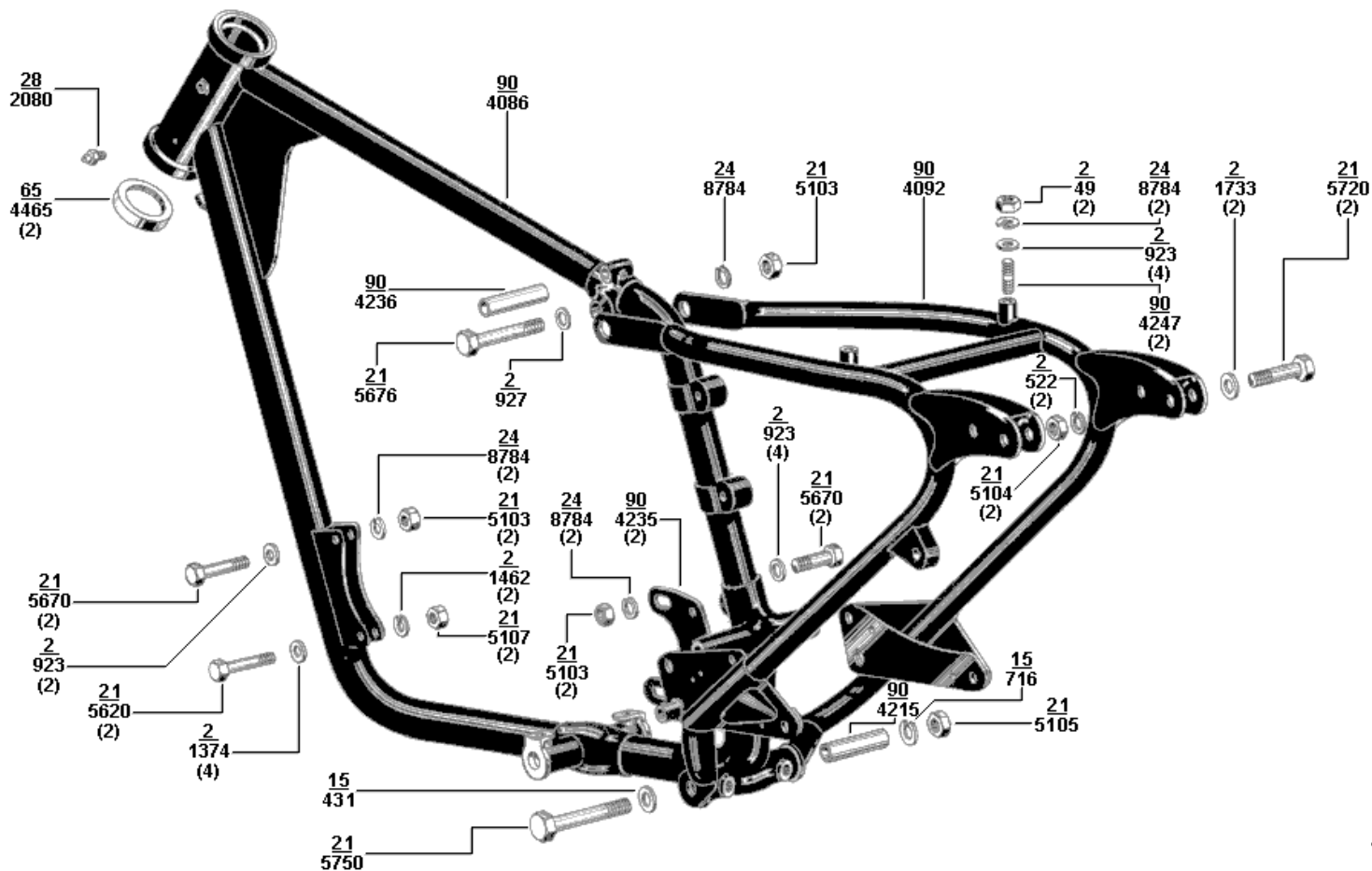

FRAME, CADRE, RAHMEN, CUADRO

Part No. No. De Commande Bestell - Nr No. DeParte	Description	Designation	Benennung	Descripción	Per Set Nombre Anzahl Juego De
2-49	Nut	Ecrou	Mutter	Tuerca	2
2-522	Lockwasher	Arrêtoir	Sicherung	Freno	2
2-923	Washer	Rondelle	Scheibe	Arandela	10
2-927	Washer	Rondelle	Scheibe	Arandela	
2-1374	Washer	Rondelle	Scheibe	Arandela	4
2-1462	Lockwasher	Arrêtoir	Sicherung	Freno	2
2-1733	Washer	Rondelle	Scheibe	Arandela	2
15-431	Washer	Rondelle	Scheibe	Arandela	
15-716	Lockwasher	Arrêtoir	Sicherung	Freno	
21-5103	Nut	Ecrou	Mutter	Tuerca	5
21-5104	Nut	Ecrou	Mutter	Tuerca	2
21-5105	Nut	Ecrou	Mutter	Tuerca	
21-5107	Nut	Ecrou	Mutter	Tuerca	2
21-5620	Bolt	Boulon	Schraube	Tornillo	2
21-5670	Bolt	Boulon	Schraube	Tornillo	4
21-5676	Bolt	Boulon	Schraube	Tornillo	
21-5720	Bolt	Boulon	Schraube	Tornillo	2
21-5750	Bolt	Boulon	Schraube	Tornillo	
24-8784	Lockwasher	Arrêtoir	Sicherung	Freno	7
28-2080	Grease Nipple	Graisieur	Schmiernppel	Engrasador	
65-4465	Bearing Cup	Cuvette De Roulement	Lagerschale	Copa De Rolamiento	2
90-4086	Frame Front	Cadre Av	Vorderrahme	Cuadro Delantro	
90-4092	Rear Sub Frame	Cadre Ar	Hinterrahme	Cuadro Trasero	
90-4215	Spacer Tube	Tube Entretoise	Abstandrhor	Tube Espaciador	
90-4235	Rear Engine Plate	Fond De Derrière	Hinterboden	Pared Posterior	2
90-4236	Spacer Tube	Tube Entretoise	Abstandrhor	Tube Espaciador	
90-4247	Stud	Goujon	Stehbolzen	Esparrago	2

FRAME AND FITTINGS

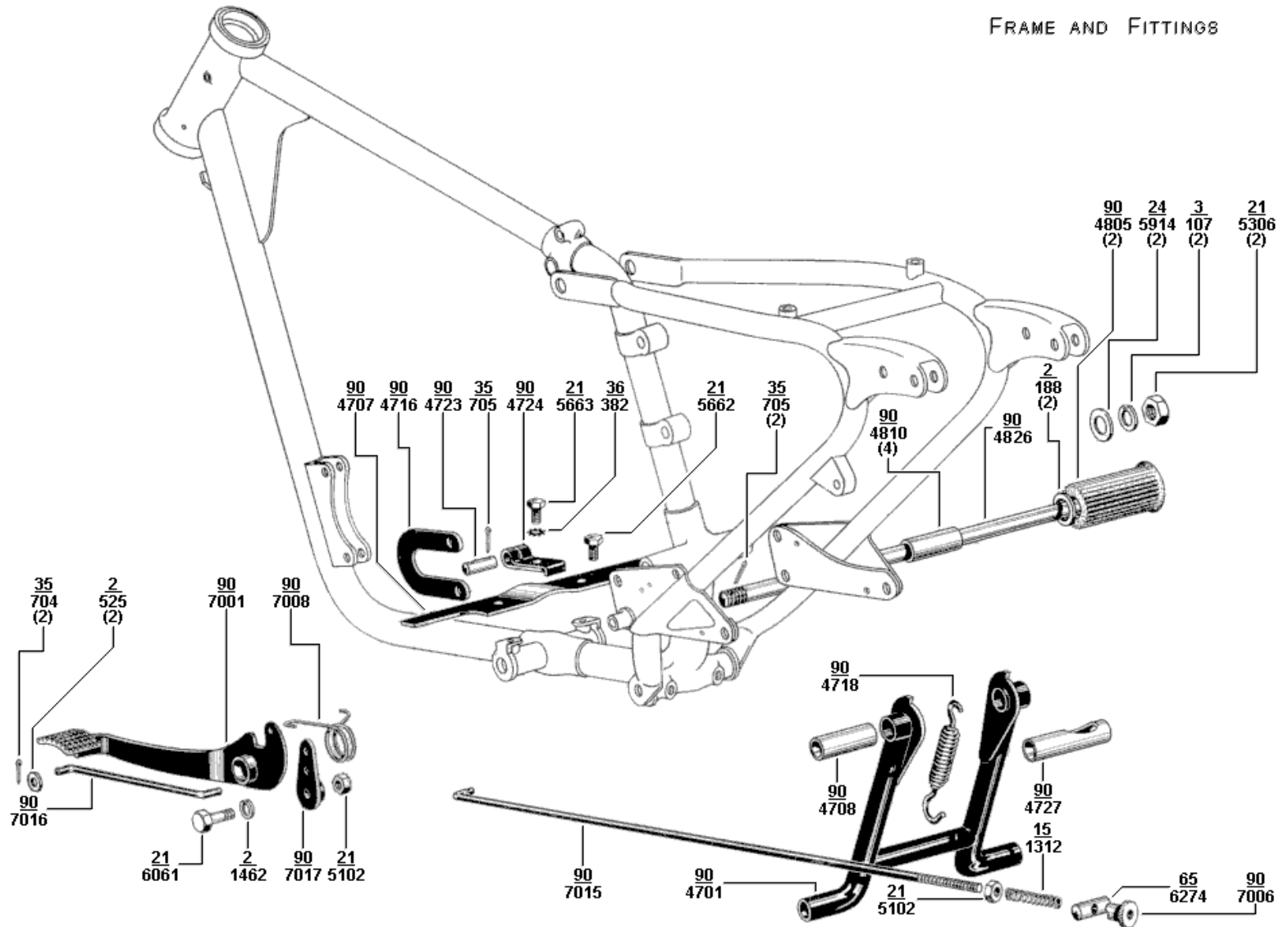

FRAME, CADRE, RAHMEN, CUADRO

Part No. No. De Commande Bestell - Nr No. DeParte	Description	Designation	Benennung	Descripción	Per Set Nombre Anzahl Juego De
2-188	Washer	Rondelle	Scheibe	Arandela	2
2-525	Washer	Rondelle	Scheibe	Arandela	2
2-1462	Lockwasher	Arrêtoir	Sicherung	Freno	2
3-107	Lockwasher	Arrêtoir	Sicherung	Freno	2
15-1312	Spring	Ressort	Feder	Resorte	
21-5102	Nut	Ecrou	Mutter	Tuerca	2
21-5306	Nut	Ecrou	Mutter	Tuerca	2
21-5662	Bolt	Boulon	Schraube	Tornillo	
21-5663	Bolt	Boulon	Schraube	Tornillo	
21-6061	Bolt	Boulon	Schraube	Tornillo	
24-5914	Washer	Rondelle	Scheibe	Arandela	2
35-704	Split Pin	Goupille	Splint	Chaveta Hendida	2
35-705	Split Pin	Goupille	Splint	Chaveta Hendida	3
36-382	Lockwasher	Arrêtoir	Sicherung	Freno	1
65-6274	Swivel Pin	Goupille	Stift	Esparrago	
90-4701	Centre Stand	Béquille	Ständer	Muleta	
90-4707	Stop Plate	Plaque D'Arret	Anschlag	Placa Limita Dora	
90-4708	Bush (L/H)	Douille (Gauche)	Buchse (Links)	Casquillo (Izq)	
90-4716	Spring Anchor Plate	Support	Halter	Sujeción	
90-4718	Spring	Ressort	Feder	Resorte	
90-4723	Pivot Pin	Axe	Bolzen	Eje	
90-4727	Bush (R/H)	Douille (Droite)	Buchse (Rechts)	Casquillo (Derecho)	
90-4805	Rubber Pad	Plaque De Caoutchouc	Gummiauflage	Placa De Goma	2
90-4810	Spacer Tube	Tube Entretoise	Abstandrhor	Tubo Espaciador	4
90-4826	Footrest Rod	Tringle Marche Pied	Fubbrettstange	Varilla Del Estribo	
90-7001	Brake Pedal	Pédale De Frein	Fussbremshebel	Pedal De Freno	
90-7006	Adjuster Nut	Ecrou De Réglage	Verstellungs Mutter	Tuerca De Ajuste	
90-7008	Spring	Ressort	Feder	Resorte	
90-7015	Brake Rod (Long)	Tringle De Frein (Longue)	Zugstange (Lange)	Triante De Freno (Largo)	
90-7016	Brake Rod (Short)	Tringle De Frein (Courte)	Zugstange (Kurze)	Triante De Freno (Corte)	
90-7017	Intermediate Lever	Levier Intermédiaire	Zwischenhebel	Palanca Intermediaria	

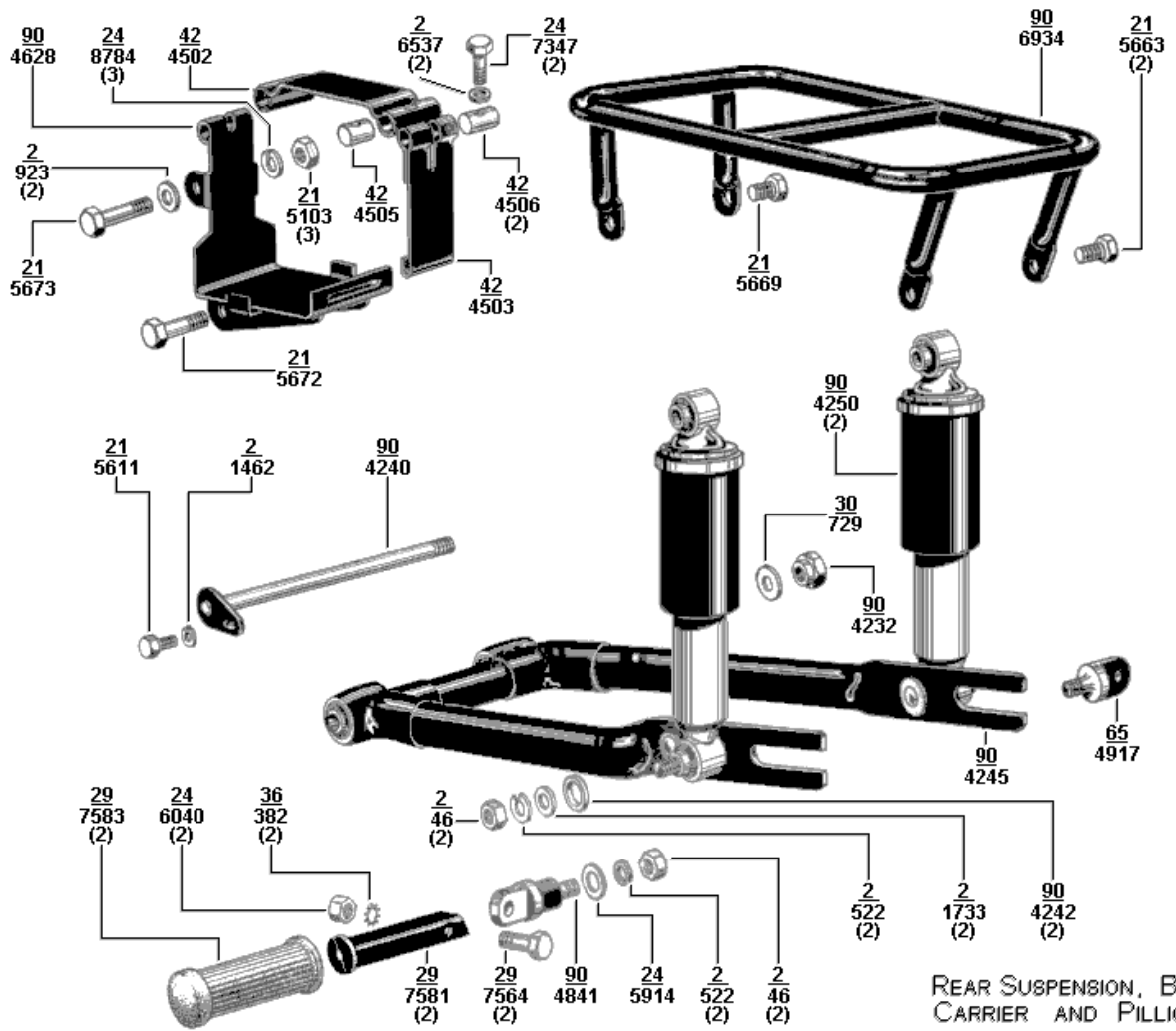

REAR SUSPENSION, BATTERY CARRIER
CARRIER AND PILLION FOOTRESTS

FRAME, CADRE, RAHMEN, CUADRO

Part No. No. De Commande Bestell - Nr No. DeParte	Description	Designation	Benennung	Descripción	Per Set Nombre Anzahl Juego De
2-46	Nut	Ecrou	Mutter	Tuerca	4
2-522	Lockwasher	Arrêtoir	Sicherung	Freno	4
2-923	Washer	Rondelle	Scheibe	Arandela	2
2-1462	Lockwasher	Arrêtoir	Sicherung	Freno	1
2-1733	Washer	Rondelle	Scheibe	Arandela	2
2-6537	Washer	Rondelle	Scheibe	Arandela	2
21-5103	Nut	Ecrou	Mutter	Tuerca	3
21-5611	Bolt	Boulon	Schraube	Tornillo	
21-5663	Bolt	Boulon	Schraube	Tornillo	2
21-5669	Bolt	Boulon	Schraube	Tornillo	
21-5672	Bolt	Boulon	Schraube	Tornillo	
21-5673	Bolt	Boulon	Schraube	Tornillo	
24-5914	Washer	Rondelle	Scheibe	Arandela	
24-6040	Nut	Ecrou	Mutter	Tuerca	2
24-7347	Bolt	Boulon	Schraube	Tornillo	2
24-8784	Lockwasher	Arrêtoir	Sicherung	Freno	3
29-7564	Bolt	Boulon	Schraube	Tornillo	2
29-7581	Footrest	Repose-Pied	Fussrast	Estribo	2
29-7583	Rubber Pad	Plaque De Caoutchouc	Gummiauflage	Placa De Goma	2
30-729	Washer	Rondelle	Scheibe	Arandela	
36-382	Lockwasher	Arrêtoir	Sicherung	Freno	2
42-4502	Battery Strap (Top)	Support De Batterie-Dessus	Batteriehälter-Oben	Suporte De Bateria-Sup.	
42-4503	Battery Strap (Side)	Support De Batterie-Côté	Batteriehälter-Seite	Suporte De Bateria-Lado.	
42-4505	Swivel Pin (Plain)	Goupille Simple	Stift	Esparrago	
42-4506	Swivel Pin (Screwed)	Goupille Filetée	Stift Mit Gewinde	Esparrago Con Rosca	2
65-4917	Anchor Bolt (R/H)	Boulon Support (Droite)	Halterschraube (Rechts)	Tornillo De Sujecion-Der	
90-4232	Nut	Ecrou	Mutter	Tuerca	
90-4240	Pivot Pin	Axe	Bolzen	Eje	
90-4242	Washer	Rondelle	Scheibe	Arandela	2
90-4245	Swinging Arm	Bras Oscillant	Schwing' Arm	Horquilla Oscillante	
90-4250	Shock Absorber	Amortisseur	Stossdämpfer	Amortiguador	2
90-4627	Battery Holder Complete	Support De Batterie Comp	Batterieträger Vollst	Porta-Bateria Comp	
90-4628	Battery Holder	Support De Batterie	Batterieträger	Porta-Bateria	
90-4840	Pillion Footrest Assy. (L/H)	Repose-Pied Ar (Gauche)	Sozius Fussrast (Links)	Estribo Tras (Izq)	
90-4841	Anchor Bolt (L/H)	Boulon Support (Gauche)	Halterschraube (Links)	Tornillo De Sujecion	
42-4845	Pillion Footrest Assy. (R/H)	Repose-Pied Ar (Gauche)	Sozius Fussrast (Links)	Estribo Tras (Der)	
90-6934	Carrier	Porte-Bagages	Trager	Porta Equipaje	

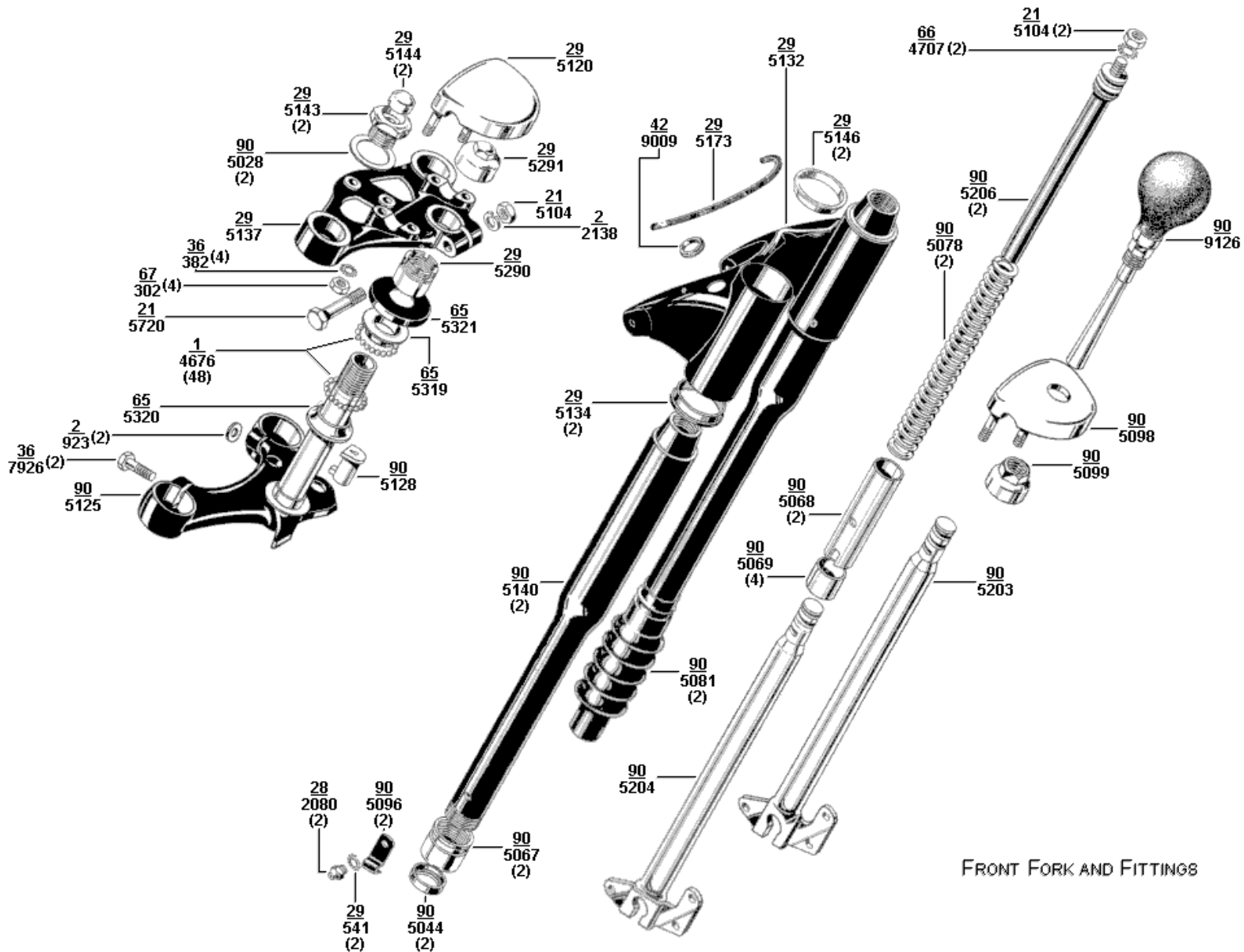

FRONT FORK AND FITTINGS

FRONT FORK, FOURCHE AV, VORDERGABEL, HORQUILLA DEL

Part No. No. De Commande Bestell - Nr No. DeParte	Description	Designation	Benennung	Descripción	Per Set Nombre Anzahl Juego De
1-4676	Ball	Bille	Kugel	Bola	48
2-923	Washer	Rondelle	Scheibe	Arandela	2
2-2138	Lockwasher	Arrêtoir	Sicherung	Freno	
21-5104	Nut	Ecrou	Mutter	Tuerca	3
21-5720	Bolt	Boulon	Schraube	Tornillo	
28-2080	Grease Nipple	Graisneur	Schmiernippel	Engrasador	2
29-541	Lockwasher	Arrêtoir	Sicherung	Freno	2
29-5120	Handlebar Cap	Bouchon De Guidon	Lenkerkappe	Tapon De Manillar	
29-5132	Bracket	Support	Lagerbock	Soporte	
29-5134	Rubber Ring	Bague Caoutchouc	Gummiring	Anillo De Goma	2
29-5137	Top Yoke	Attache Supérieure	Oberjoch	Horqueta Superior	
29-5143	Nut	Ecrou	Mutter	Tuerca	2
29-5144	Cap	Rondelle Chapeau	Abdeckkappe	Tapon	2
29-5146	Spacer Bush	Bague D'Ecartement	Distanzring	Anillo Espaciador	2
29-5173	Rubber Moulding	Profilé Caoutchouc	Profilgummi	Profil De Goma	
29-5290	Adjuster	Vis Molletée	Schraube	Tornillo	
29-5291	Nut	Ecrou	Mutter	Tuerca	
36-382	Lockwasher	Arrêtoir	Sicherung	Freno	4
36-7926	Bolt	Boulon	Schraube	Tornillo	2
42-9009	Rubber Grommet	Manchon Caoutchouc	Gummitülle	Manguera De Goma	
65-5319	Bearing Cone (Upper)	Cone (Supérieure)	Lagerkonus (Oben)	Cona De Cojinete (Sup)	
65-5320	Bearing Cone (Lower)	Cone (Inférieure)	Lagerkonus (Unten)	Cona De Cojinete (Inf)	
65-5321	Cover	Capeau De Protection	Schutzkappe	Tapa	
66-4707	Lockwasher	Arrêtoir	Sicherung	Freno	2
67-302	Nut	Ecrou	Mutter	Tuerca	4
90-5028	Washer	Rondelle	Scheibe	Arandela	2
90-5044	Oil Seal	Joint D'Huile	Dichtring	Reten De Aceite	2
90-5067	Lower Nut	Ecrou Inférieure	Mutter Unten	Tuerca Inferior	2
90-5068	Spacer Tube	Tube Entretoise	Abstandrhör	Tubo Espaciador	2
90-5069	Bush	Douille	Büchse	Casquillo	2
90-5078	Spring	Ressort	Feder	Resorte	2
90-5081	Tube Gaiter	Manche De Tube	Rohrhülse	Manguera De Tubo	2
90-5096	Locking Plate	Arrêtoir	Sicherung	Freno	2
90-5098	Handlebar Cap	Bouchon De Guidon	Lenkerkappe	Tapon De Manillar	
90-5099	Nut	Ecrou	Mutter	Tuerca	
90-5125	Bottom Yoke	Attache Inférieure	Unterjoch	Horqueta Inferior	
90-5128	Lock	Serrure	Schloss	Cerradura	
90-5140	Outer Tube	Tube Extérieure	Aussenrohr	Tubo Exterior	2
90-5202	Fork Complete	Fourche Avant Complète	Vordergabel Vollst	Horquilla Del Comp.	
90-5203	Sliding Tube (R/H)	Tube Coulissant-Droite	Schieberrohr Rechts	Tubo Deslizando (Der)	
90-5204	Sliding Tube (L/H)	Tube Coulissant-Gauche	Schieberrohr Links	Tubo Deslizando (Izq)	
90-5206	Top Scroll Assy.	Ancrage Du Ressort	Federanker	Sujeción Del Resorte	2
90-9126	Bulb Horn	Avertisseur A Poire	Birnhorn	Bocina A Pera	

*Used with Direct Lighting
*Pour Modèles avec Éclairage Directe

*Für Modellen Mit Direckter Eichleistung
*Para Modelos con Lucas Directas

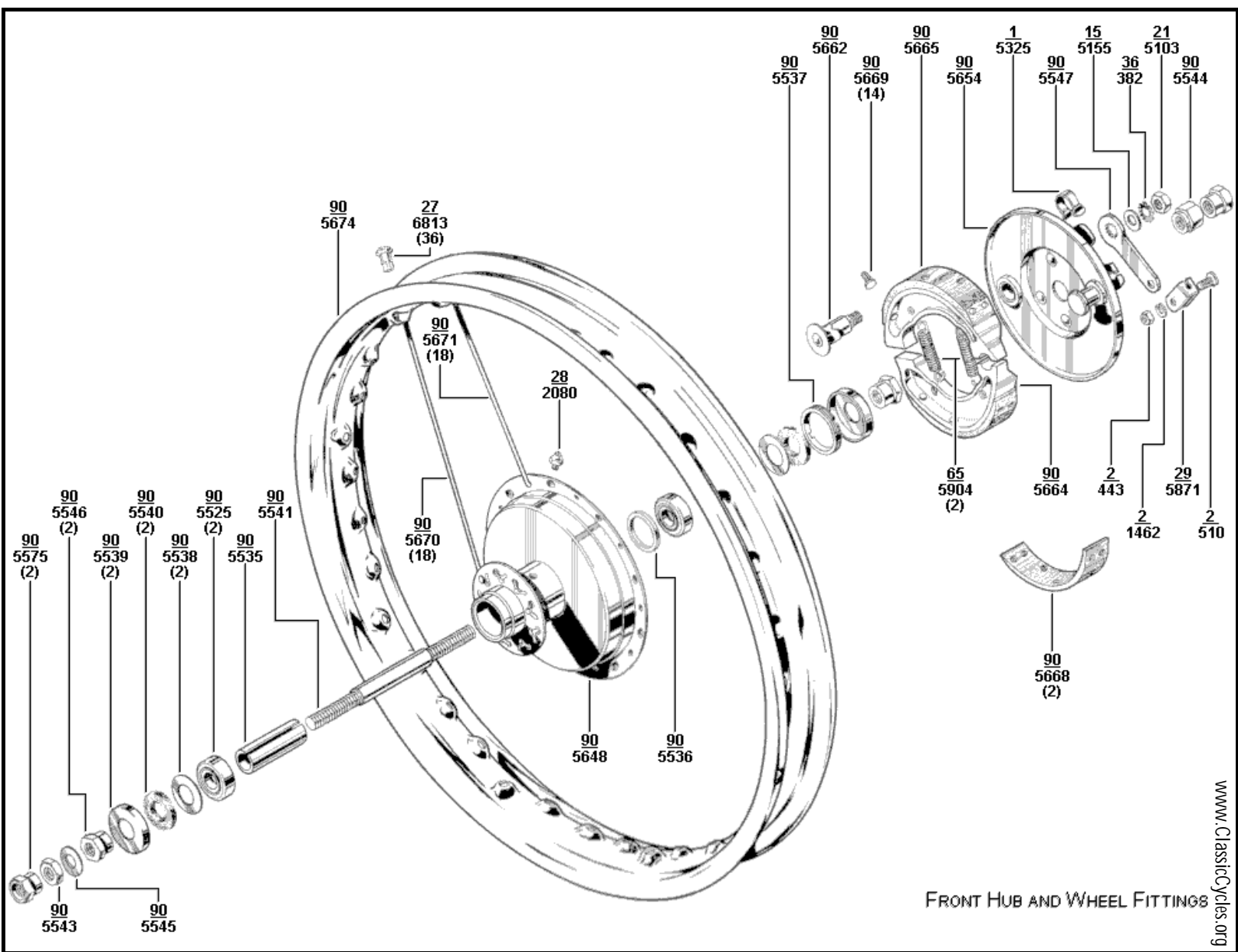

FRONT HUB AND WHEEL FITTINGS

FRONT WHEEL, ROUE AV, VORDERRAD, RUEDA DELANTRA

Part No. No. De Commande Bestell - Nr No. DeParte	Description	Designation	Benennung	Descripción	Per Set Nombre Anzahl Juego De
1-5325	Oil Hole Cover	Couvercle Du Trou D'Huile	Öllochdeckel	Tapa Del Agujero De Lubrication	
2-443	Nut	Ecrou	Mutter	Tuerca	
2-510	Screw	Vis	Schraube	Tornillo	
2-1462	Lockwasher	Arrêtoir	Sicherung	Freno	
12-5155	Washer	Rondelle	Scheibe	Arandela	
21-5103	Nut	Ecrou	Mutter	Tuerca	
27-6813	Nipple	Ecrou	Nippel	Tuerca	36
28-2080	Grease Nipple	Graisneur	Schmiernppel	Engrasador	
29-5871	Toggle	Rotule	Knebelgelenk	Junta De Codillo	
36-382	Lockwasher	Arrêtoir	Sicherung	Freno	
65-5904	Spring	Ressort	Feder	Resorte	2
90-5525	Ball Bearing	Roulement	Lager	Rolamiento	
90-5535	Spacer Tube	Tube Entretoise	Abstandrohr	Tubo Espaciador	
90-5536	Spacer Ring	Bague	Ring	Anillo Espaciador	
90-5537	Lock Ring	Arrêtoir	Sicherung	Freno	
90-5538	Washer	Rondelle	Scheibe	Arandela	
90-5539	Cover	Chapeau De Protection	Schutzkappe	Tapa	2
90-5540	Felt Washer	Rondelle Feutre	Filz Scheibe	Arandela De Filtro	2
90-5541	Axle	Axe	Achse	Eje	
90-5543	Nut	Ecrou	Mutter	Tuerca	
90-5544	Nut	Ecrou	Mutter	Tuerca	
90-5545	Washer	Rondelle	Scheibe	Arandela	
90-5546	Nut	Ecrou	Mutter	Tuerca	2
90-5547	Brake Cam Lever	Levier De Frein	Bremshebel	Palanca De Freno	
90-5575	Nut	Ecrou	Mutter	Tuerca	2
90-5647	Front Hub	Moyeu De Roue Av.	Vorderradnabe	Cubo De Rueda Del	
90-5648	Hub Shell	Corps De Moyeu	Nabenkorper	Cuerpo De Cubo	
90-5654	Brake Back Plate	Disque De Frein	Bremsscheibe	Disco De Freno	
90-5662	Brake Cam	Clé de Frein	Bremsschlüssel	Llave De Freno	
90-5664	Brake Shoe	Segment	Bremssbacke	Zapata	
90-5665	Brake Shoe	Segment	Bremssbacke	Zapata	
90-5668	Brake Lining	Garniture	Belag	Guarnición	2
90-5669	Rivet	Rivet	Niet	Remanche	14
90-5670	Spoke	Rayon	Speiche	Raio	18
90-5671	Spoke	Rayon	Speiche	Raio	18
90-5674	Rim	Jante	Felge	Llanta	
90-5675	Front Wheel	Roue Av.	Vorderrad	Rueda Delantera	

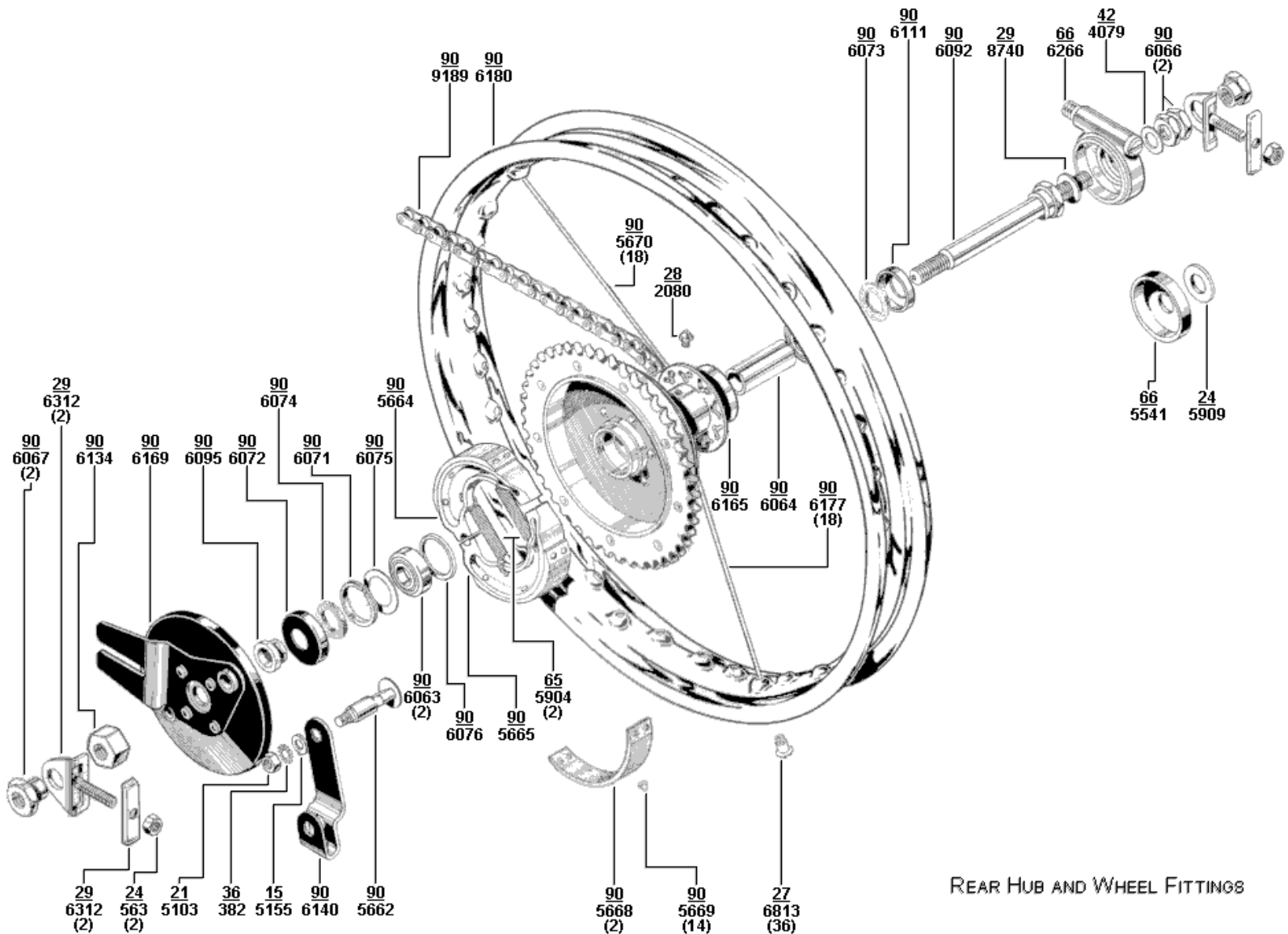

REAR HUB AND WHEEL FITTINGS

REAR WHEEL, ROUE AR, HINTERRAD, RUEDA TRASERA

Part No. No. De Commande Bestell - Nr No. DeParte	Description	Designation	Benennung	Descripción	Per Set Nombre Anzahl Juego De
15-5155	Washer	Rondelle	Scheibe	Arandela	
21-5103	Nut	Ecrou	Mutter	Tuerca	
24-563	Nut	Ecrou	Mutter	Tuerca	2
24-5909	Washer	Rondelle	Scheibe	Arandela	
27-6813	Nipple	Ecrou	Nippel	Tuerca	36
28-2080	Grease Nipple	Graisieur	Schmiernppel	Engrasador	
29-6312	Adjuster Cap	Couvercle	Kappe	Tapón	2
29-6313	Adjuster	Vis Mollettée	Schraube	Tornillo	2
29-8740	Washer	Rondelle	Scheibe	Arandela	
36-382	Lockwasher	Arrêtoir	Sicherung	Freno	
42-4079	Washer	Rondelle	Scheibe	Arandela	
65-5904	Spring	Ressort	Feder	Resorte	2
66-5541	Cover	Chapeau De Protection	Schutzkappe	Tapa	
66-6266	Speedo Gearbox	Entraînement Du Compteur	Tachoantrieb	Accionamiento Del Velocimetro	
90-5562	Brake Cam	Clé de Frein	Bremsschlüssel	Llave De Freno	
90-5664	Brake Shoe	Segment	Bremsbacke	Zapata	
90-5665	Brake Shoe	Segment	Bremsbacke	Zapata	
90-5668	Brake Lining	Garniture	Belag	Guarnición	2
90-5669	Rivet	Rivet	Niet	Remanche	14
90-5670	Spoke	Rayon	Speiche	Raio	18
90-6063	Ball Bearing	Roulement	Lager	Rolamiento	2
90-6064	Spacer Tube	Tube Entretoise	Abstandrohr	Tubo Espaciador	
90-6066	Nut	Ecrou	Mutter	Tuerca	2
90-6067	Nut	Ecrou	Mutter	Tuerca	2
90-6071	Locking Ring	Arrêtoir	Sicherung	Freno	
90-6072	Cover	Chapeau De Protection	Schutzkappe	Tapa	
90-6073	Felt Washer	Rondelle Feutre	Filzscheibe	Arandela De Fieltro	
90-6074	Felt Washer	Rondelle Feutre	Filzscheibe	Arandela De Fieltro	
90-6075	Washer	Rondelle	Scheibe	Arandela	
90-6076	Spacer Ring	Bague	Ring	Anillo Espaciador	
90-6092	Axle	Axe	Achse	Eje	
90-6095	Spacer Bush	Bague D'Ecartement	Distanzring	Anillo Espaciador	
90-6111	Retaining Cup	Cuvette	Halte Tasse	Receptaculo	
90-6134	Nut	Ecrou	Mutter	Tuerca	
90-6140	Brake Cam Lever	Levier De Frein	Bremshebel	Palanca De Freno	
90-6164	Rear Hub	Moyeu De Roue Ar	Hinterradnabe	Cubo De Rueda Tras.	
90-6165	Hub Shell	Corps De Moyeu	Nabenkorper	Cuerpo De Cubo	
90-6169	Brake Back Plate	Disque De Frein	Bremsscheibe	Disco De Freno	
90-6177	Spoke	Rayon	Speiche	Raio	
90-6178	Rear Wheel	Roue Ar	Hinterrad	Rueda Trasera	
90-6180	Rim	Jante	Felge	Llanta	
90-9198	Chain	Chaîne	Kette	Cadena	

REAR MUDGUARD

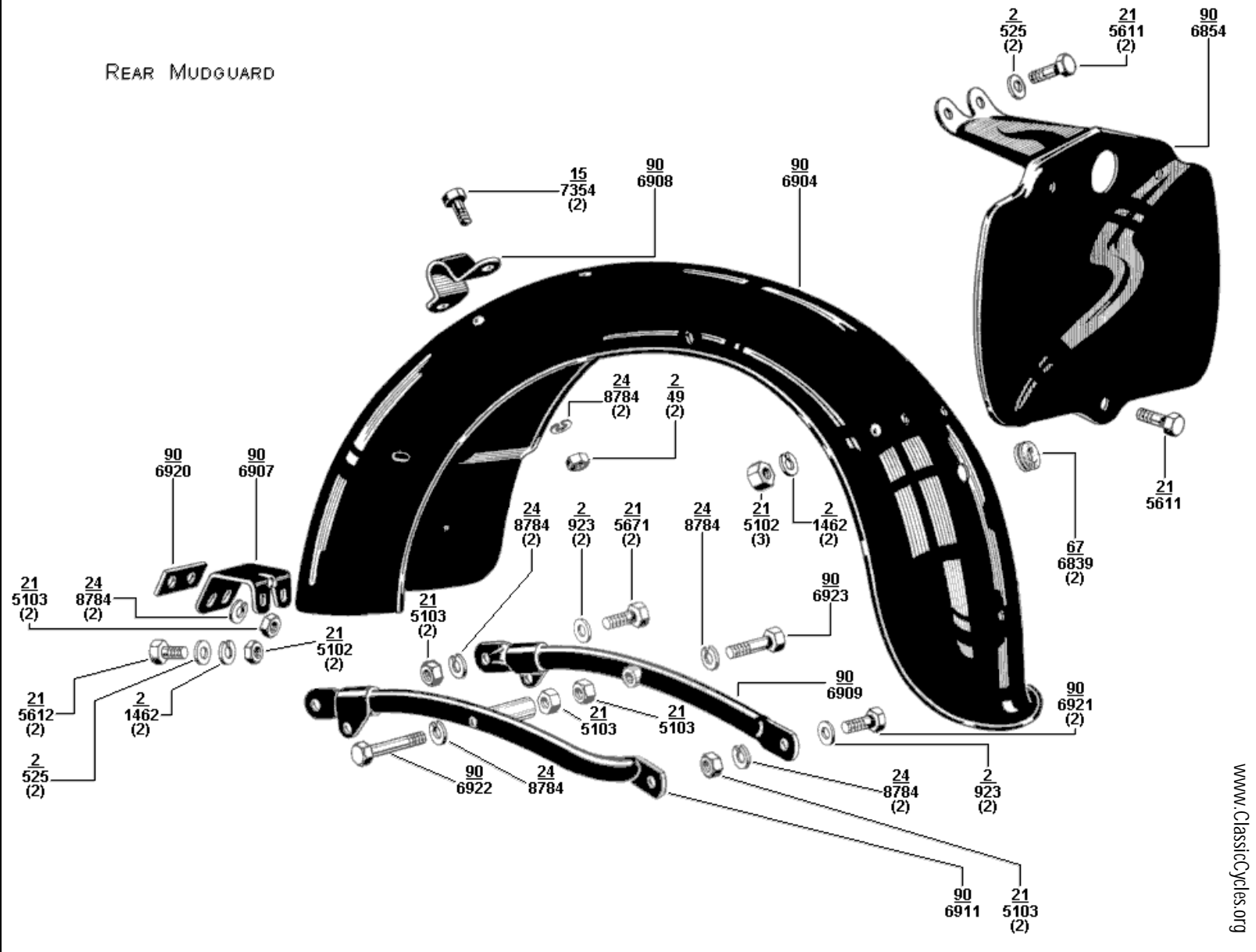

MUDGUARDS, GARDEBOUE, SCHUTZBLECHE, GUARDABARROS

Part No. No. De Commande Bestell - Nr No. DeParte	Description	Designation	Benennung	Descripción	Per Set Nombre Anzahl Juego De
2-49	Nut	Ecrou	Mutter	Tuerca	2
2-525	Washer	Rondelle	Scheibe	Arandela	4
2-923	Washer	Rondelle	Scheibe	Arandela	4
2-1462	Lockwasher	Arrêtoir	Sicherung	Freno	5
15-7354	Bolt	Boulon	Schraube	Tornillo	2
21-5102	Nut	Ecrou	Mutter	Tuerca	5
21-5103	Nut	Ecrou	Mutter	Tuerca	8
21-5611	Bolt	Boulon	Schraube	Tornillo	3
21-5612	Bolt	Boulon	Schraube	Tornillo	2
21-5671	Bolt	Boulon	Schraube	Tornillo	2
24-8784	Lockwasher	Arrêtoir	Sicherung	Freno	10
67-6839	Rubber Grommet	Manchon Caoutchouc	Gummiau Flage	Manguera De Goma	2
90-6854	Number Plate	Plaque De Police	Kennzeichenschild	Chapa De Patente	
90-6904	Rear Mudguard	Garde-Boue De Roue Ar	Hinterradschutzblech	Guarda Barro-Tras	
90-6907	Bracket	Support	Halter	Soporte	
90-6908	Clip	Collier De Serrage	Klemmring	Abrazadera	
90-6909	Stay (R/H)	Tringle Droite	Strebe Rechts	Tirante Derecho	
90-6911	Stay (L/H)	Tringle Gauche	Strebe Links	Tirante Izquierdo	
90-6920	Plate	Plaque	Scheibe	Placa	
90-6921	Bolt	Boulon	Schraube	Tornillo	2
90-6922	Bolt	Boulon	Schraube	Tornillo	
90-6923	Bolt	Boulon	Schraube	Tornillo	

MUDGUARD, CHAINGUARD AND TOOLBOX

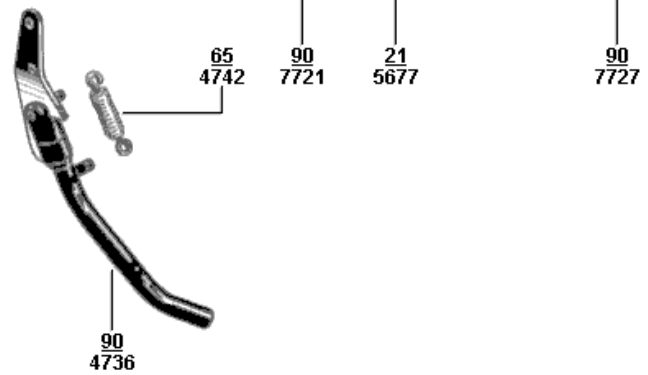
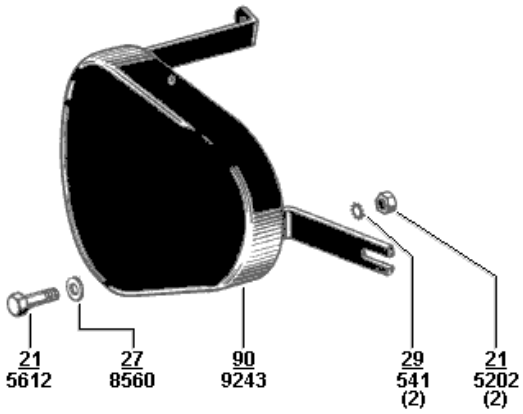
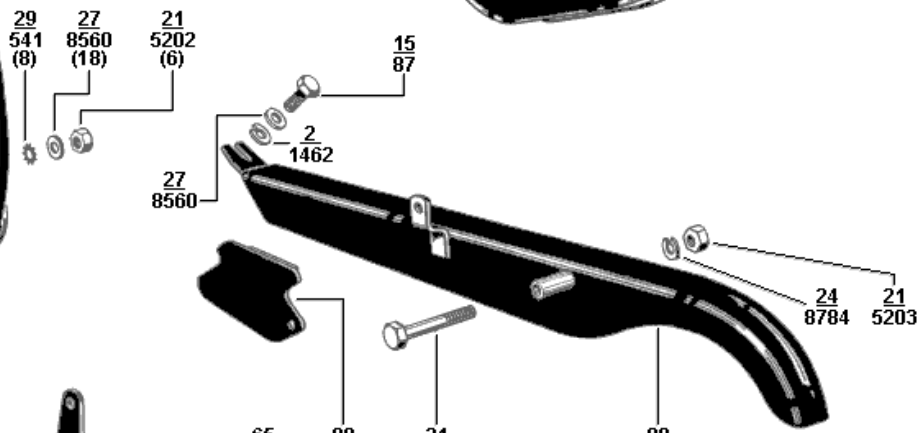
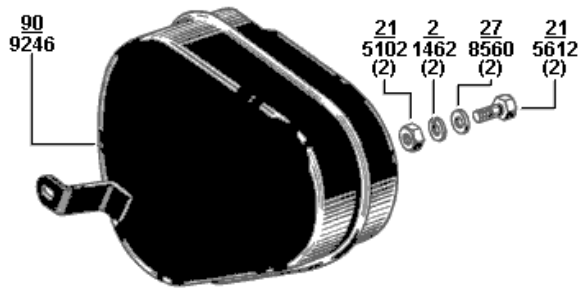
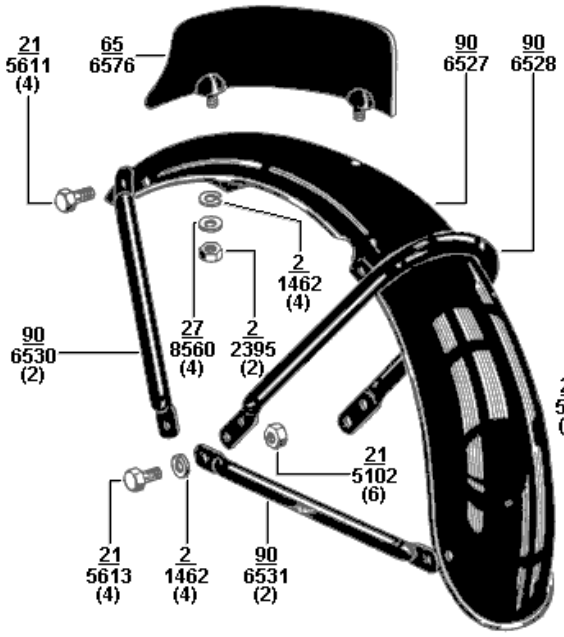

**MUDGUARDS, GARDEBOUE, SCHUTZBLECHE, GUARDABARROS
CHAINGUARDS, CARTER DE CHAÎNE, KETTERNKASTEN, GUARDACADENA
TOOLBOX, COFFRET À OUTILS, WERKZEUGBENHÄLTER, CAJA DE HERRAMIENTAS**

Part No. No. De Commande Bestell - Nr No. DeParte	Description	Designation	Benennung	Descripción	Per Set Nombre Anzahl Juego De
2-1462	Lockwasher	Arrêteoir	Sicherung	Freno	9
2-2395	Nut	Ecrou	Mutter	Tuerca	2
15-87	Bolt	Boulon	Schraube	Tornillo	
21-5102	Nut	Ecrou	Mutter	Tuerca	8
21-5103	Nut	Ecrou	Mutter	Tuerca	1
21-5202	Nut	Ecrou	Mutter	Tuerca	8
21-5611	Bolt	Boulon	Schraube	Tornillo	4
21-5612	Bolt	Boulon	Schraube	Tornillo	3
21-5613	Bolt	Boulon	Schraube	Tornillo	4
21-5677	Bolt	Boulon	Schraube	Tornillo	
24-8784	Lockwasher	Arrêteoir	Sicherung	Freno	
27-8560	Washer	Rondelle	Scheibe	Arandela	24
29-541	Lockwasher	Arrêteoir	Sicherung	Freno	10
65-4742	Spring	Ressort	Feder	Resorte	
65-6576	Number Plate	Plaque De Police	Kennzeichenschild	Chapa De Patente	
90-4736	Prop Stand	Béquille Latérale	Seitenstütze	Muleta Lateral	
90-6527	Front Mudguard	Garde-Boue De Roue Av.	Vorderradschutzblech	Guardabarro Del	
90-6528	Stay	Tringle	Strebe	Tirante	
90-6530	Stay	Tringle	Strebe	Tirante	2
90-6531	Stay	Tringle	Strebe	Tirante	2
90-7721	Extension	Rallongement	Verlängerung	Extensión	
90-7727	Chainguard	Carter De Chaîne	Ketternkasten	Guardacadena	
90-9243	Cover	Chapeau De Protection	Schutzkappe	Tapa	
90-9246	Toolbox	Coffret À Outils	Werkzeugbehälter	Caja De Herramientas	

DUAL SEAT AND FITTINGS,
SADDLE

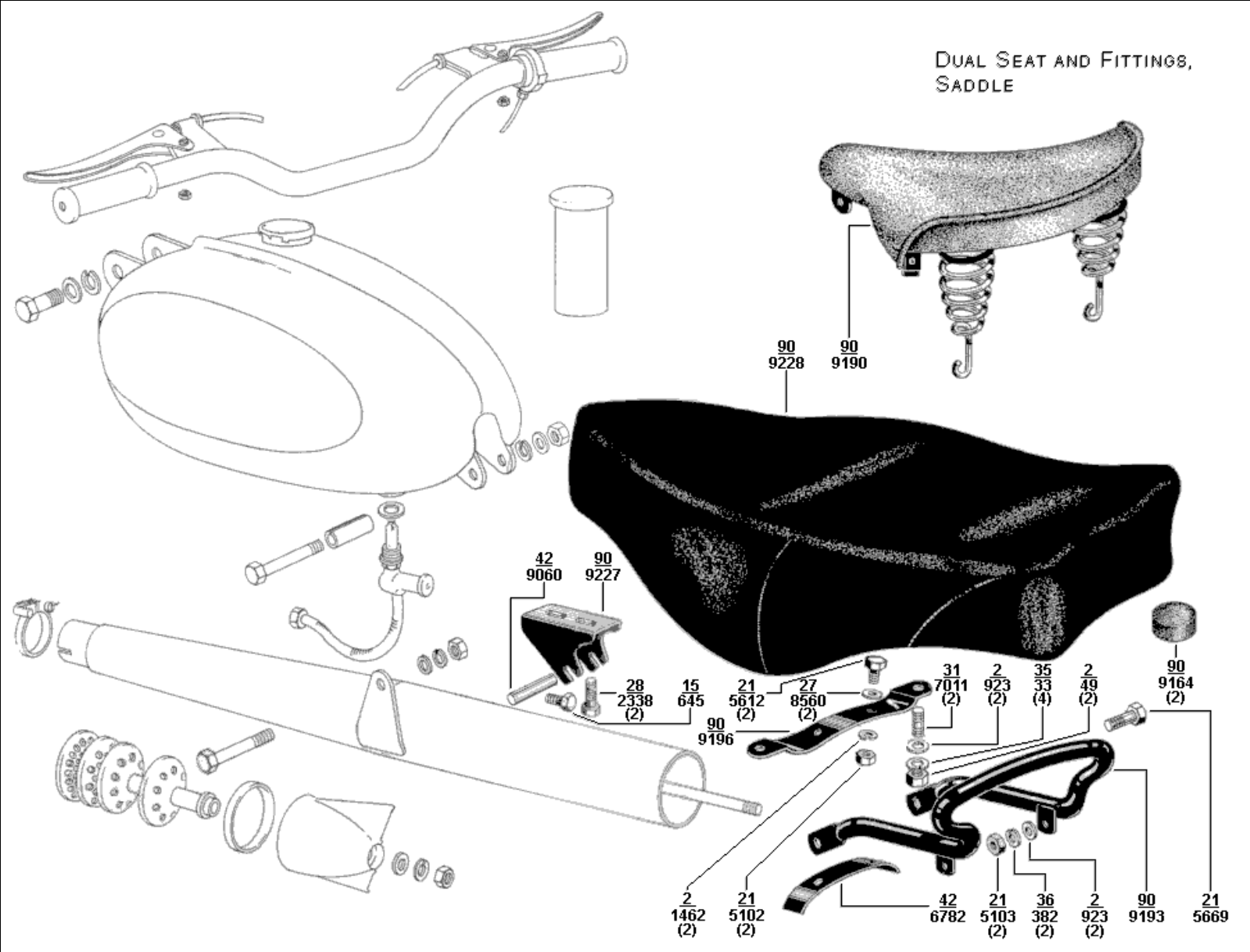

DUAL SEAT, SELLE DOUBLE, DOPPELSITZ, ASIENTO DOBLE

Part No. No. De Commande Bestell - Nr No. DeParte	Description	Designation	Benennung	Descripción	Per Set Nombre Anzahl Juego De
2-49	Nut	Ecrou	Mutter	Tuerca	2
2-923	Washer	Rondelle	Scheibe	Arandela	8
2-1462	Lockwasher	Arrêtoir	Sicherung	Freno	2
15-645	Bolt	Boulon	Schraube	Tornillo	
21-5102	Nut	Ecrou	Mutter	Tuerca	2
21-5103	Nut	Ecrou	Mutter	Tuerca	2
21-5612	Bolt	Boulon	Schraube	Tornillo	2
21-5669	Bolt	Boulon	Schraube	Tornillo	
27-8560	Washer	Rondelle	Scheibe	Arandela	2
28-2338	Bolt	Boulon	Schraube	Tornillo	2
31-7011	Stud	Goujon	Stehbolzen	Esparrago	2
35-33	Lockwasher	Arrêtoir	Sicherung	Freno	4
36-382	Lockwasher	Arrêtoir	Sicherung	Freno	2
42-6782	Bracket	Support	Lagerbock	Soporte	
42-9060	Support Pin	Goupille De Support	Haltebolzen	Esparrago	
90-9164	Rubber Buffer	Silent-Bloc	Dämpfer	Amortiguador	
90-9190	Saddle	Selle	Sattel	Sillín	
90-9193	Handrail	Poignée	Griff	Puño	
90-9196	Support Bracket	Support	Halter	Soporte	
90-9227	Support Bracket	Support	Halter	Soporte	
90-9228	Dual Seat Complete	Delle Double Complète	Doppelsitz Vollst	Asiento Doble Comp.	
90-9229	Dual Seat Fittings	Accessoires De Selle Double	Beschläge Der Doppelsitz	Acces. Del Asiento Doble.	

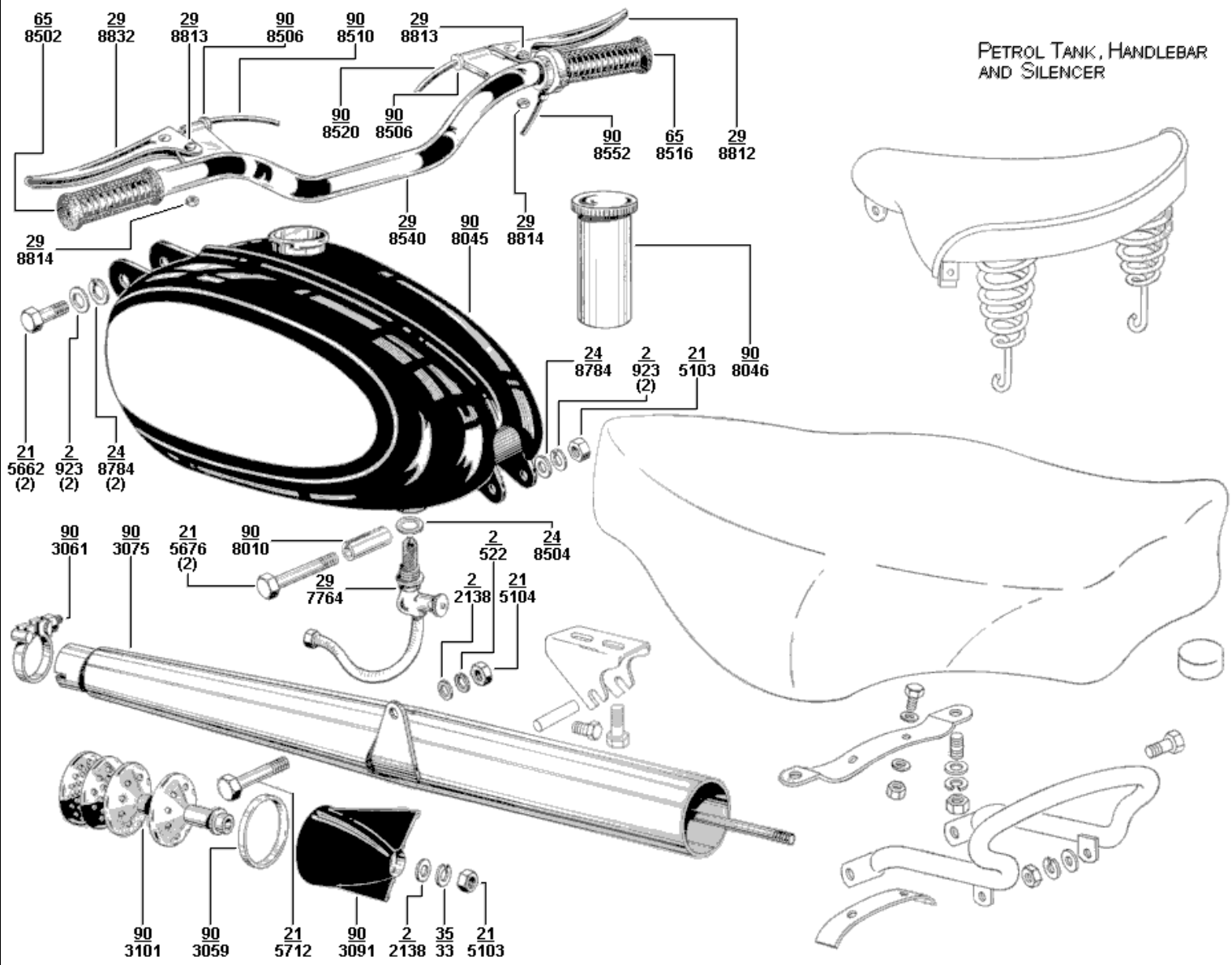

**PETROL TANK, RESEVOIR à CARBURANT, KRAFTSTOFFBEHÄLTER, DEPOSITO de COMBUSTIBLE
HANDLEBAR, GUIDON, LENKER, MANILLAR
SILENCER, SILENCIEUX, AUSPUFFTOPF, SILENCIADOR**

Part No. No. De Commande Bestell - Nr No. DeParte	Description	Designation	Benennung	Descripción	Per Set Nombre Anzahl Juego De
2-49	Nut	Ecrou	Mutter	Tuerca	
2-522	Lockwasher	Arrêtoir	Sicherung	Freno	
2-923	Washer	Rondelle	Scheibe	Arandela	4
2-2138	Washer	Rondelle	Scheibe	Arandela	2
21-5103	Nut	Ecrou	Mutter	Tuerca	2
21-5104	Nut	Ecrou	Mutter	Tuerca	
21-5662	Bolt	Boulon	Schraube	Tornillo	2
21-5676	Bolt	Boulon	Schraube	Tornillo	
21-5712	Bolt	Boulon	Schraube	Tornillo	
24-8504	Sealing Washer	Joint	Dichtung	Reten	
24-8784	Lockwasher	Arrêtoir	Sicherung	Freno	3
29-7764	Petrol Pipe with Tap	Tuyau A Essence Avec Robinet	Benzinschlauch	Caño De Benzina	
29-8812	Brake Lever	Levier De Frein	Bremshebel	Palanca De Freno	
29-8813	Screw	Vis	Schraube	Tornillo	2
29-8814	Nut	Ecrou	Mutter	Tuerca	2
29-8832	Clutch Lever	Levier Pour Embrayage	Kupplungs Hebel	Palanca Del Embrague	
35-33	Lockwasher	Arrêtoir	Sicherung	Freno	
65-8502	Grip	Tube De Poignée	Griffrohr	Puño	
65-8516	Twist Grip	Poignée Tournante De Commande De Gaz	Vergaser-Drehgriff	Puño Girante De Acelerador	
90-3059	Sealing Ring	Bague D'Etanchéité	Dichtring	Retén	
90-3061	Clip Complete	Bride Complète	Klammer Vollst	Grapa Completa	
90-3075	Silencer Body	Corps Du Silencieux	Auspufftopfkörper	Cuerpo Del Silenciador	
90-3091	Silencer Fishtail	Silencieux-Partie Queue De Poisson	Auspufftopf-Fischschwanz	Cola De Pescado Del Silenciador	
90-3100	Silencer Complete	Silencieux Complète	Auspufftopf Vollst	Silenciador Comp	
90-3101	Silencer Baffle	Intérieur De Silencieux	Flöterohr	Interior Del Silenciador	
90-8010	Spacer Tube	Tube Entretoise	Abstandrohr	Tubo Espaciador	
90-8045	Petrol Tank	Réservoir De Carburant	Kraftstoffbehälter	Deposito De Combustible	
90-8046	Filler Cap	Bouchon De Réservoir	Verschluss	Tapa	
90-8506	Ferrule	Virole	Prägring	Virola	2
90-8510	Clutch Cable	Câble Bowden De Commande De L'Embrayage	Seilzug Für Kupp-Lung	Cable Bowden Para Embrague	
90-8520	Front Brake Cable	Câble Bowden De Commande Du Frein Avant	Seilzug Für Vorder-Radbrenise	Cable Bowden Para Freno Delatero	
29-8540	Handlebar	Guidon	Lenker	Manillar	
90-8552	Throttle Cable	Câble Bowden De Commande Du Carburateur	Seilzug Für Vergaser	Cable Bowden Para Acelerador	

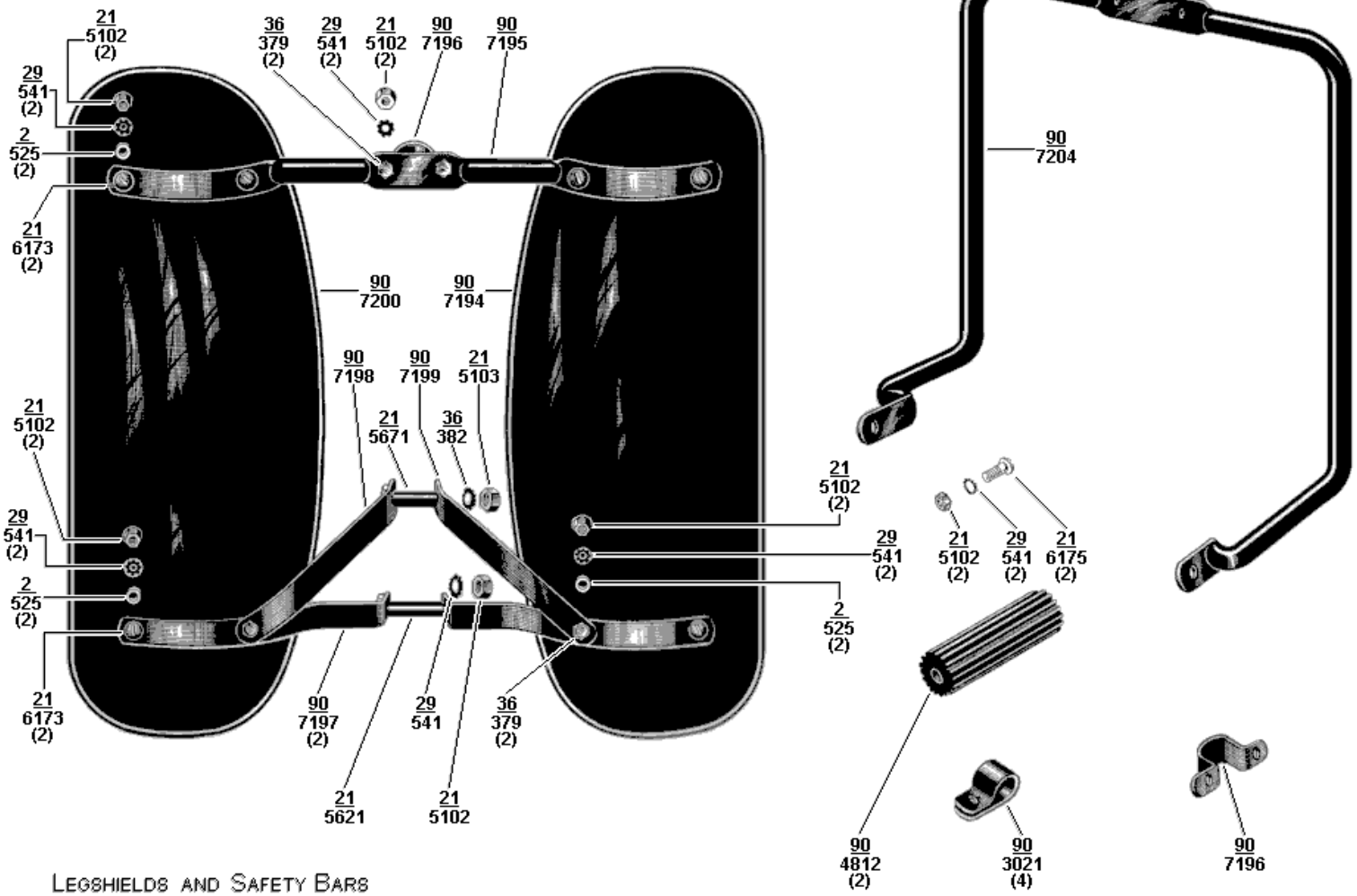

LEGSHIELDS AND SAFETY BARS

LEGSHIELDS, PROTEGE-JAMBE, BEINSCHILD, GUARDAPIERNAS SAFETY BARS, PARE-CHOCS, STURZBOGEN, BARRAS DE SEGURIDAD

Part No. No. De Commande Bestell - Nr No. DeParte	Description	Designation	Benennung	Descripción	Per Set Nombre Anzahl Juego De
2-525	Washer	Rondelle	Scheibe	Arandela	8
21-5102	Nut	Ecrou	Mutter	Tuerca	13
21-5103	Nut	Ecrou	Mutter	Tuerca	
21-5621	Bolt	Boulon	Schraube	Tornillo	
21-5671	Bolt	Boulon	Schraube	Tornillo	
21-6173	Screw	Vis	Schraube	Tornillo	6
21-6175	Screw	Vis	Schraube	Tornillo	2
29-541	Lockwasher	Arrêtoir	Sicherung	Freno	13
36-379	Bolt	Boulon	Schraube	Tornillo	4
36-382	Lockwasher	Arrêtoir	Sicherung	Freno	
90-3021	Clip	Collier De Serrage	Klemmring	Abrazadera	4
90-4812	Rubber Pad	Plaque De Caoutchouc	Gummiauflage	Placa De Goma	2
90-7193	Legshield Complete	Protège-Jambes Complète	Beinschild Vollst	Guardafango Para Piernas— Comp.	
90-7194	Legshield (L/H)	Protège-Jambes-Gauche	Beinschild (Links)	Guardafango Para Piernas— Izq.	
90-7195	Stay	Tringle	Strebe	Tirante	
90-7196	Clip	Collier De Serrage	Klemmring	Abrazadera	
90-7197	Stay	Tringle	Strebe	Tirante	
90-7198	Stay (R/H)	Tringle (Droite)	Strebe (Rechts)	Tirante (Derecho)	
90-7199	Stay (L/H)	Tringle (Gauche)	Strebe (Links)	Tirante (Izquierdo)	
90-7200	Legshield (R/H)	Protège-Jambes (Droite)	Beinschild (Rechts)	Guardafango Para Piernas— Derecho	
90-7203	Safety Bar Complete	Pre-Chocs. Complète	Sturzbogen. Komp	Barra De Seguridad Comp.	
90-7204	Safety Bar	Pre-Chocs	Sturzbogen	Barra De Seguridad	

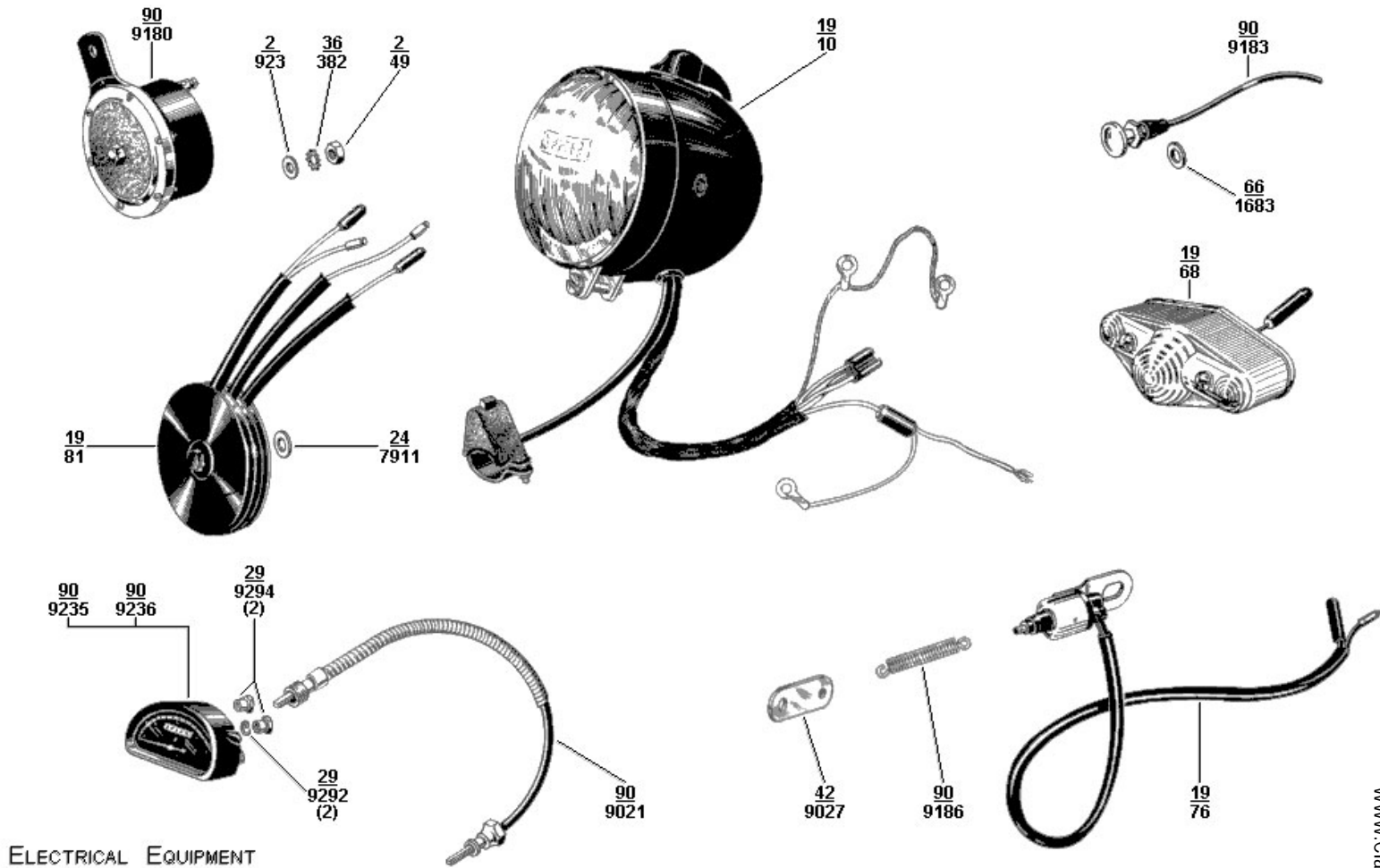

ELECTRICAL EQUIPMENT

ELECTRICAL EQUIPMENT, EQUIPEMENT ELECTRIQUE ELEKTR. AUSRÜSTUNG, EQUIPO ELECTRICO

Part No. No. De Commande Bestell - Nr No. DeParte	Description	Designation	Benennung	Descripción	Per Set Nombre Anzahl Juego De
2-49	Nut	Ecrou	Mutter	Tuerca	
2-923	Washer	Rondelle	Scheibe	Arandela	
19-10	Headlamp Unit	Phare Complete	Scheinwerfer. Komp	Faro Completa	
19-68	Rear Lamp	Feu Rouge Arrière	Schlusslampe	Luz Rota Trasera	
19-76	Stop Lamp Switch	Interrupteur De Feu "Stop"	Bremslichtschalter	Interuptor Para La Luz "Stop"	
19-81	Rectifier	Redresseur	Gleichrichter	Rectificador	
24-7911	Washer	Rondelle	Scheibe	Arandela	
29-9292	Lockwasher	Arrêtoir	Sicherung	Freno	2
29-9294	Nut	Ecrou	Mutter	Tuerca	2
36-382	Lockwasher	Arrêtoir	Sicherung	Freno	
42-9027	Stop Lamp Link	Connection Du Feu "Stop"	Stoplichtgelenk	Eslabon De Luz "Stop"	
66-1683	Washer	Rondelle	Scheibe	Arandela	
90-9021	Drive Shaft	Arbe D'Entrainement	Antriebs Welle	Arbol De Transmisión	
90-9180	Horn	Avertisseur	Signalhorn	Bocina	
90-9183	Horn Push	Bouton D'Avertisseur	Hornknopf	Botón De Bocina	
90-9186	Spring	Ressort	Feder	Resorte	
90-9235	Speedometer Head (m.p.h.)	Compteur De Vitesse (m.p.h.)	Tachometer (m.p.h.)	Velocimetro (m.p.h.)	
90-9236	Speedometer Head (k.p.h.)	Compteur De Vitesse (k.p.h.)	Tachometer (k.p.h.)	Velocimetro (k.p.h.)	

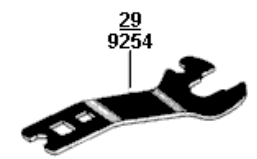
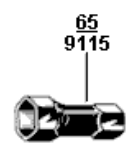
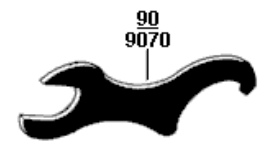
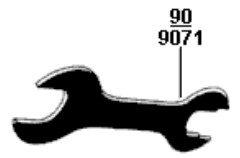
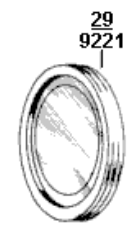
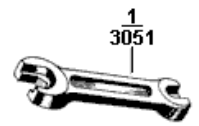
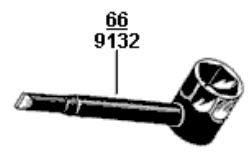
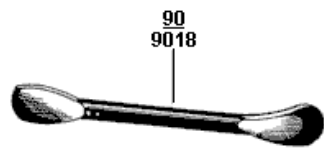
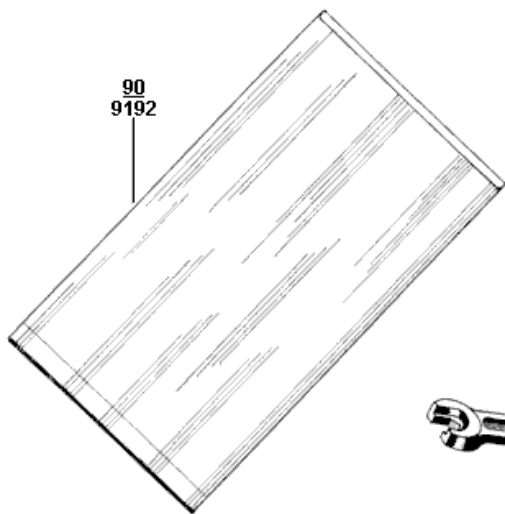

TOOLS AND SUNDRIES

TOOLS, OUTILS, WERKZEUGER, HERRAMIENTOS

Part No. No. De Commande Bestell - Nr No. DeParte	Description	Designation	Benennung	Descripción	Per Set Nombre Anzahl Juego De
1-3051	Double Ended Spanner	Clé À Fourche Double	Doppelschraubenschlüssel	Llave De Dos Bocas	
29-9221	Licence Holder	Porte Permet	Licenzhalter	Portalicencia	
29-9254	Double Ended Spanner	Clé À Fourche Double	Doppelschraubenschlüssel	Llave De Dos Bocas	
65-9115	Box Spanner	Clé À Douille	Steckschlüssel	Llave De Tubo	
66-9049	Rubber Strap	Bande Caoutchouc	Gummiband	Cinta De Goma	
66-9132	Box Spanner	Clé À Douille	Steckschlüssel	Llave De Tubo	
90-9018	Tyre Lever	Démonte-Pneu	Reifenheber	Palanca Desmonta Neumaticos	
90-9024	Rubber Strap	Bande Caoutchouc	Gummiband	Cinta De Goma	
90-9070	Double Ended Spanner	Clé À Fourche Double	Doppelschraubenschlüssel	Llave De Dos Bocas	
90-9071	Double Ended Spanner	Clé À Fourche Double	Doppelschraubenschlüssel	Llave De Dos Bocas	
90-9192	Tool Bag	Trousse À Outils	Werkzeughülle	Bolsa De Herramientas	
90-9237	Inflator	Pompe À Air	Luftpumpe	Bomba De Aire	
90-9012	Tool Kit Complete	Outilsage Complete	Werkzeug Vollst	Herramientas Comp.	

PISTONS

Model	Comp. Ratio	PISTONS COMPLETE			COMPRESSION RINGS		
		Standard	.020 O.S.	.040 O.S.	Standard	.020 O.S.	.040 O.S.
D5	7.5	90-1305	90-1349	90-1351	90-1311	90-1312	90-1313

CARBURETTER AND SETTINGS

MESSRS. AMALGAMATED CARBURETTERS LTD., PERRY BARR, BIRMINGHAM.

Part. No.	Type	Choke Size (inches)	Main Jet	Pilot Jet	Throttle Valve No.	Needle Jet	Needle Position	Engine End Size (Inches)
90-1379	375/31	7/8	140	25	375/3½	.1055	4	7/8